

TANK DATA	
DESIGNED TO	AS1692, UL 142, UL2085
BUILT TO	UL142, UL2085
GROSS VOLUME	10,700l
SAFE FILL LEVEL	10,000l
PNEUMATIC TEST	21-35 kPa (INNER & OUTER)
PAINT - EXTERNAL	BASE - HEMPADUR 17360, 50µm INTERMEDIATE - HEMPADUR 15560, 100µm TOP - HEMPADUR 55610, 50µm
PAINT COLOUR	HEMPEL 10000 HIGH-GLOSS WHITE
WEIGHT	7,482 KG

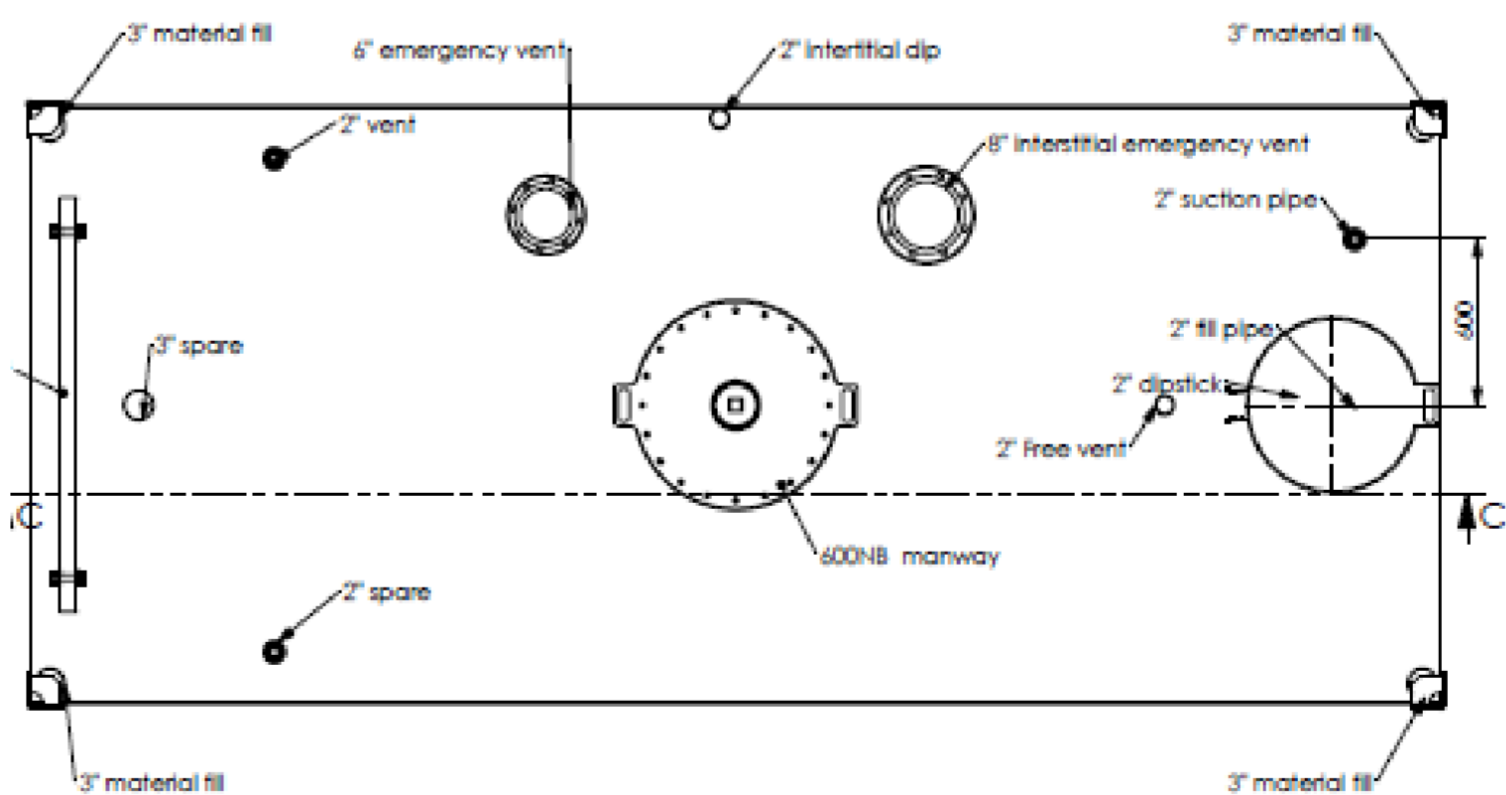

**IF IN DOUBT ASK.  
DRAWING INFORMATION TAKES PRECEDENCE OVER PARTS LIST**

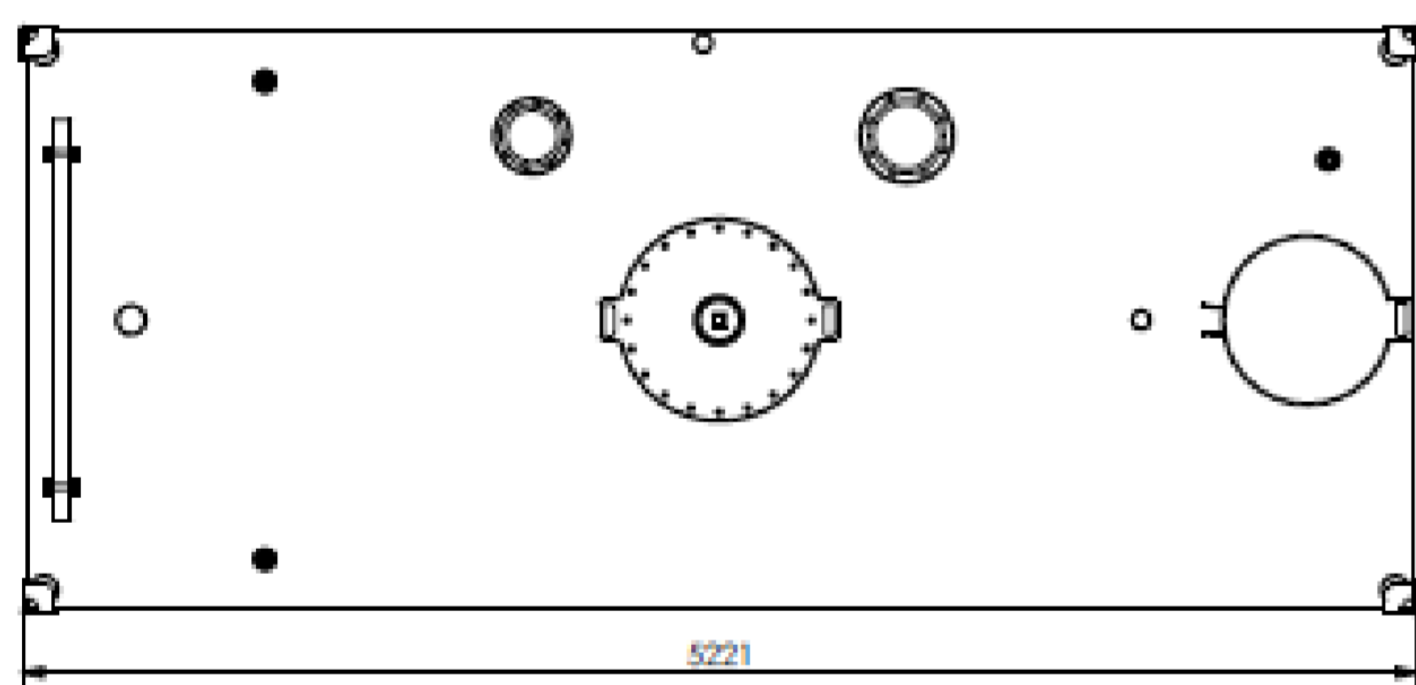
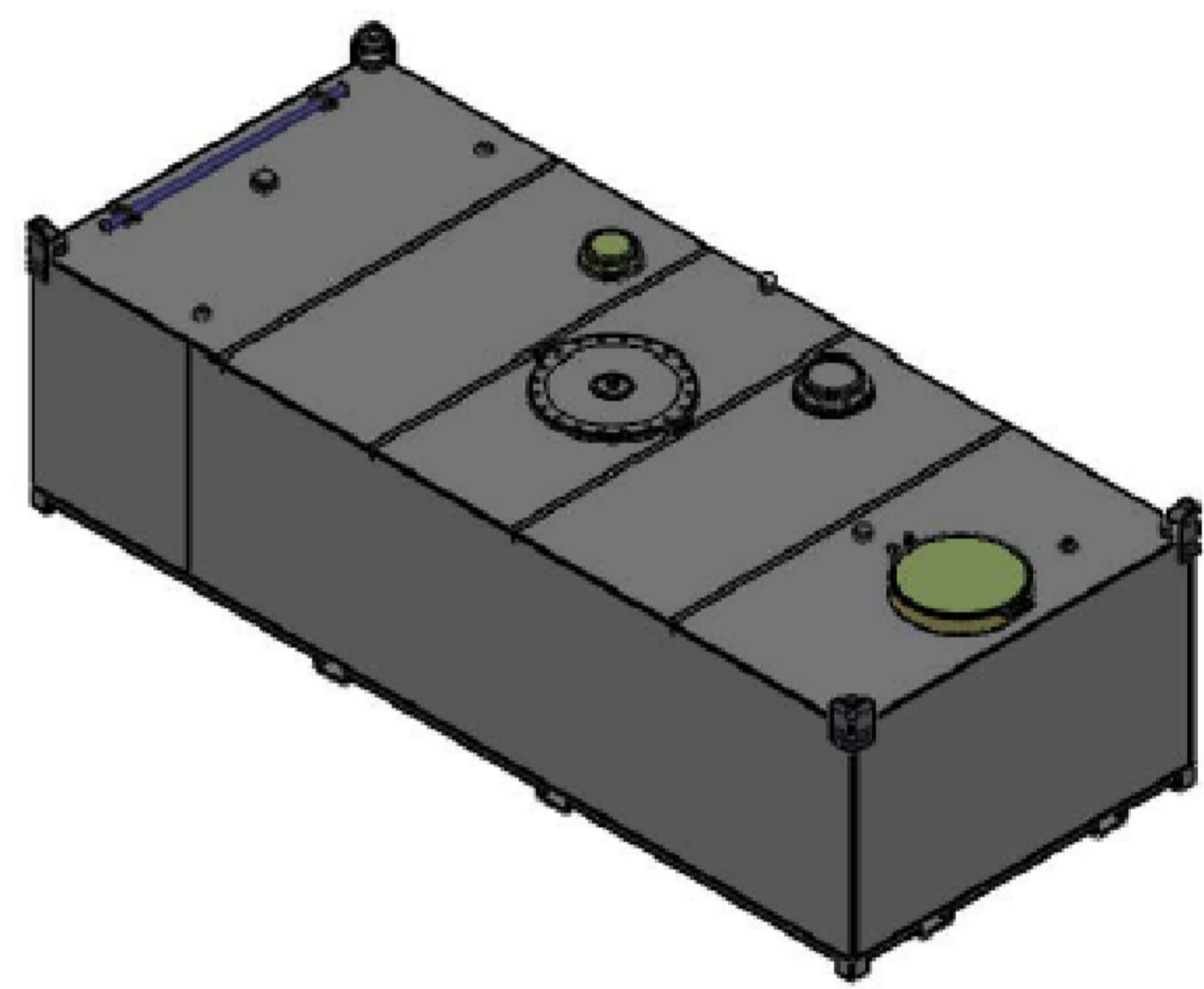
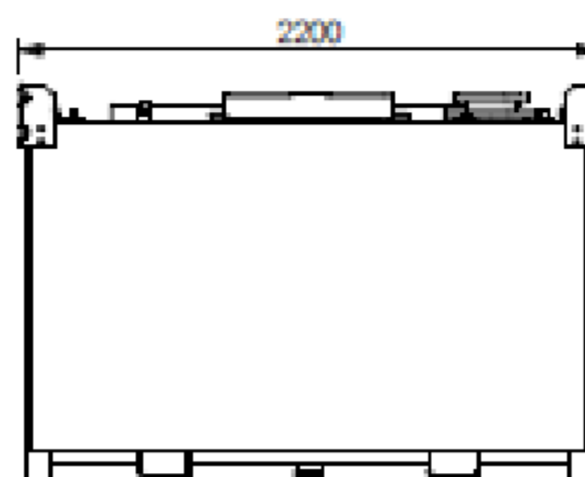
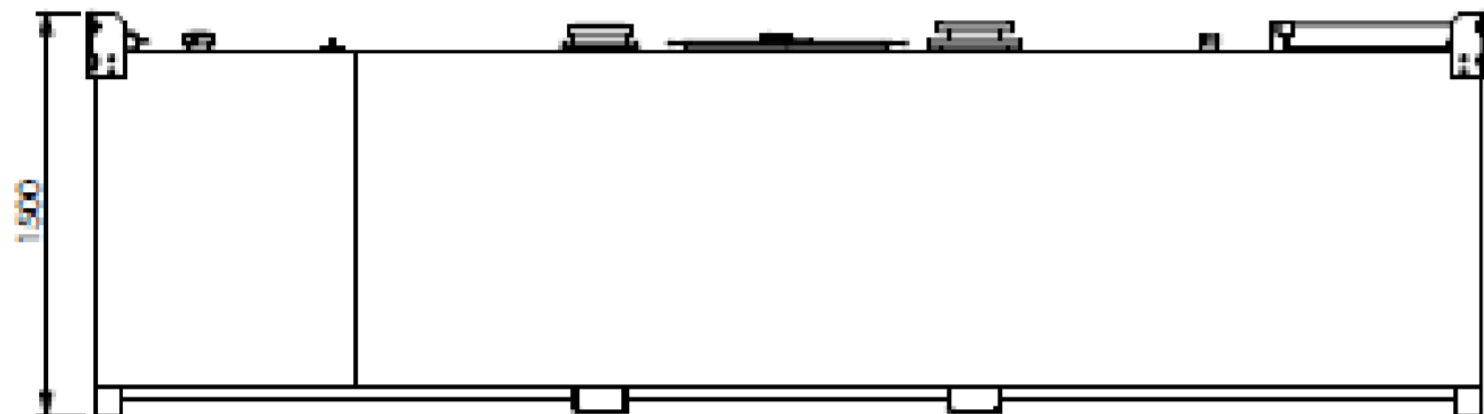

GENERAL NOTES		
DO NOT SCALE		
UNLESS STATED OTHERWISE- ALL DIMENSIONS IN MILLIMETERS		
ALL THREADS ARE METRIC COARSE		
DEBURR & REMOVE ALL SHARP EDGES		
TOLERANCES:		
TYPE	RANGE	TOLERANCE
LINEAR (mm)	0 - 100	±2.0
	101 - 1000	±10.0
	> 1000	±20.0
ANGULAR (minutes)		±0.1*

SCALE	2:1
DWN	MB
DATE	17/09/2018
CLIENT	NA
END USER	NA

TITLE	
10000L Fire Rated Tank	
SHEET 1 OF 1	
DRAWING NUMBER	REV A