

DO NOT SCALE FROM DRAWING. IF IN DOUBT: ASK

UNLESS OTHERWISE SPECIFIED, ALL DIMENSIONS ARE IN MILLIMETRES

BEWARE OF 100mm MEASURING ERROR

TANK DATA	
TANK CONTENTS:	DIESEL/AdBlue
DESIGNED TO:	AS1940
BUILT TO:	AS1692,CAT.3
CORROSION ALLOW:	0mm
GROSS VOLUME:	73,308L/7,310L
HYD.TEST PRESSURE:	Gross level+150mm
SAFE FILL LEVEL:	69,308L/6,945L
N.D.T	
TOTAL MASS:	16,648KG

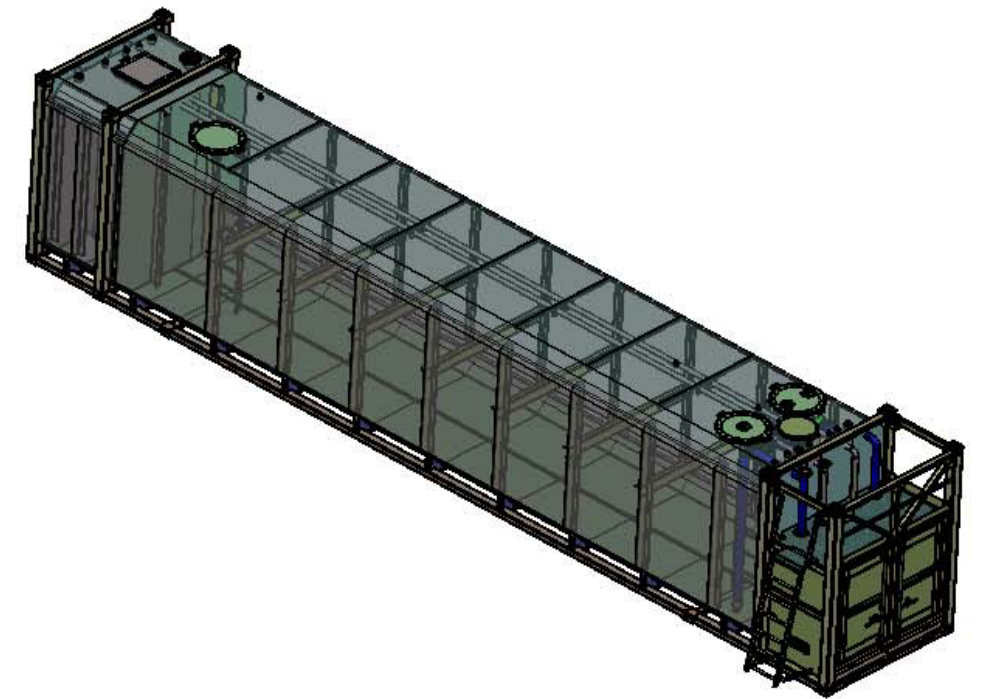
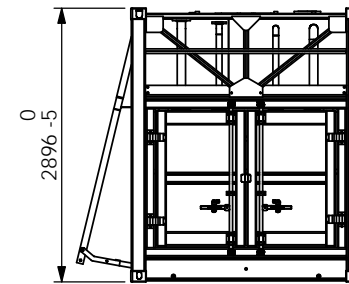
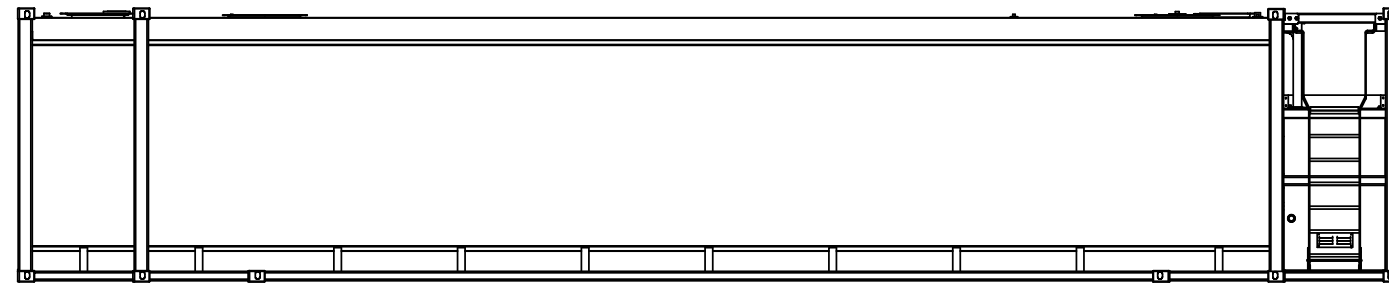
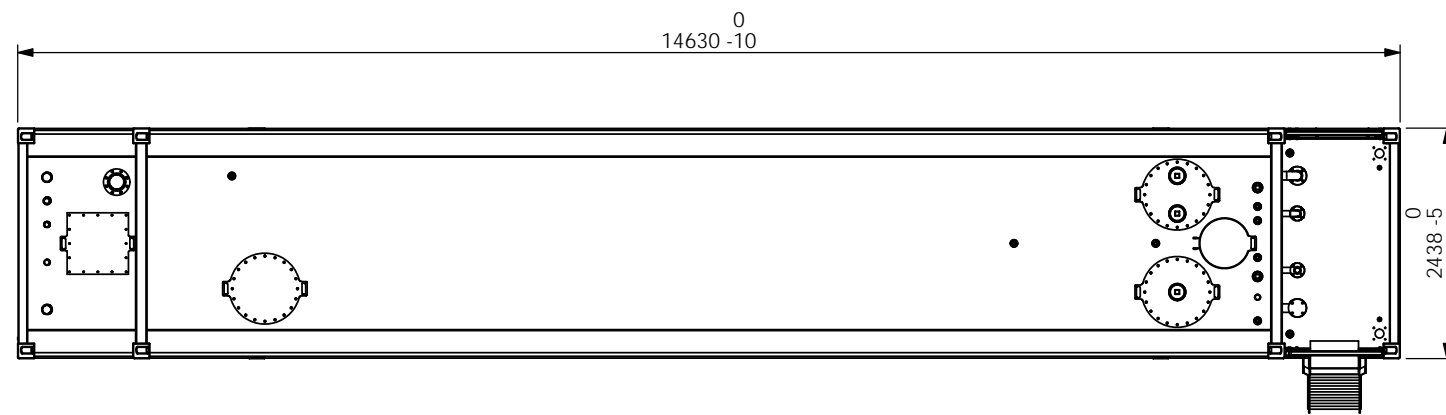

THIRD ANGLE PROJECTION	
○	
NAME	DATE
DRAWN	2016/6/23
CHK'D	
APP'VD	



TOLERANCE U.N.O.
 0 = -1.0
 0.0 = -0.4
 0.00 = -0.1

MATERIAL:
 WEIGHT: 16536.65 Kg

DWG NO. / PART NO.	JOB NO.
CLIENT: 80,000L GO CON-AB SELF BUNDED TANK	
TITLE:	SHEET SIZE A3
SCALE: N.T.S.	REVISION 01
SHEET 1 OF 2	

DO NOT SCALE FROM DRAWING. IF IN DOUBT: ASK

UNLESS OTHERWISE SPECIFIED, ALL DIMENSIONS ARE IN MILLIMETRES

BEWARE OF 100mm MEASURING ERROR

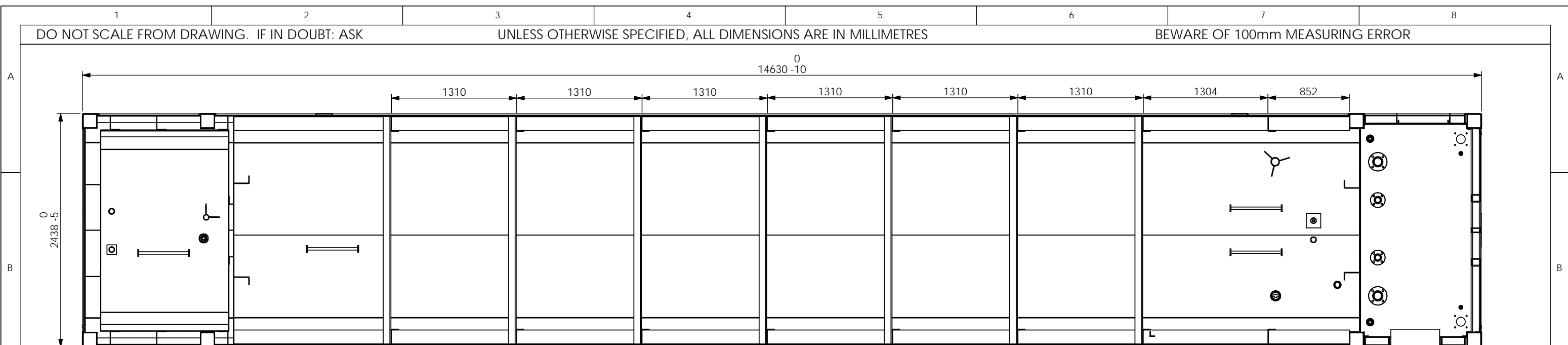

剖面 B-B

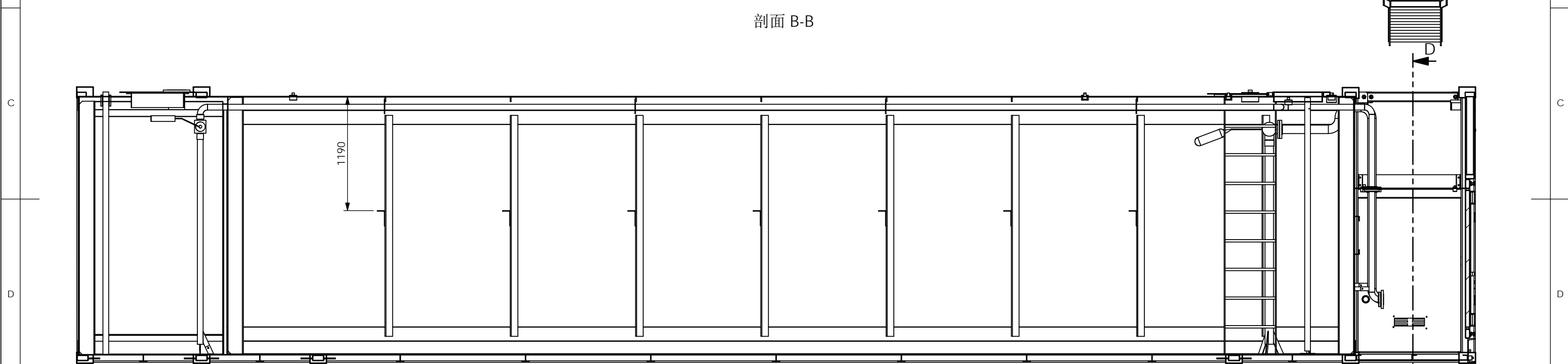

剖面 C-C

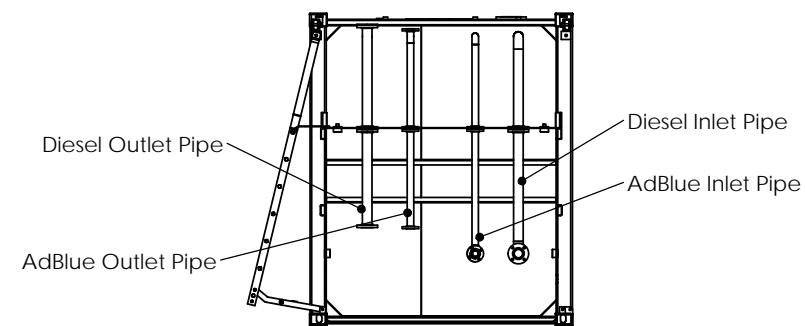
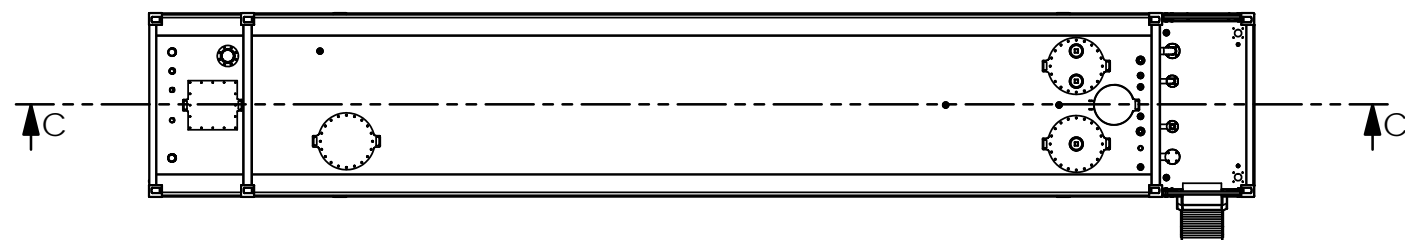

剖面 D-D

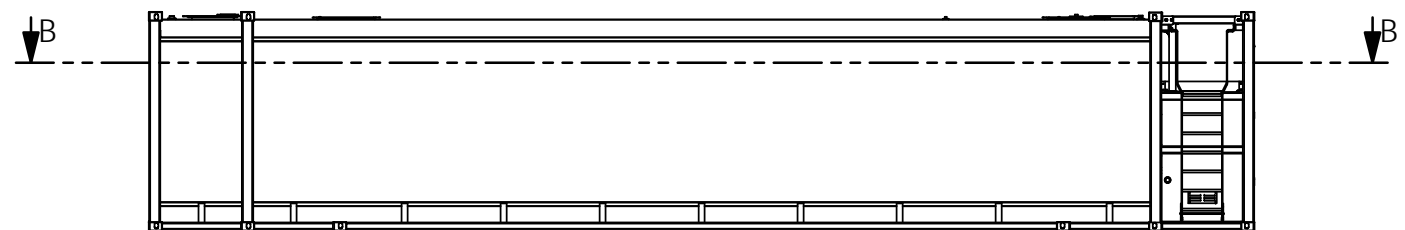

THIRD ANGLE PROJECTION		
DRAWN	2016/6/23	
CHK'D		
APP'VD		

TOLERANCE U.N.O.	MATERIAL:
0 = -1.0	
0.0 = -0.4	
0.00 = -0.1	WEIGHT: 16536.65 Kg

DWG NO. / PART NO.	JOB NO.
CLIENT: 80,000L GO CON-AB SELF BUNDED TANK	
TITLE:	
SCALE: N.T.S.	SHEET 2 OF 2
SHEET SIZE A3	
REVISION 01	