

DO NOT SCALE FROM DRAWING. IF IN DOUBT: ASK

UNLESS OTHERWISE SPECIFIED, ALL DIMENSIONS ARE IN MILLIMETRES

BEWARE OF 100mm MEASURING ERROR

TANK DATA	
TANK CONTENTS:	DIESEL/AdBlue
DESIGNED TO:	AS1940
BUILT TO:	AS1692,CAT.3
CORROSION ALLOW:	0mm
GROSS VOLUME:	59,950L/7,016L
HYD.TEST PRESSURE:	Gross level+150mm
SAFE FILL LEVEL:	56,952L/6,666L
N.D.T	
TOTAL MASS:	14,015KG

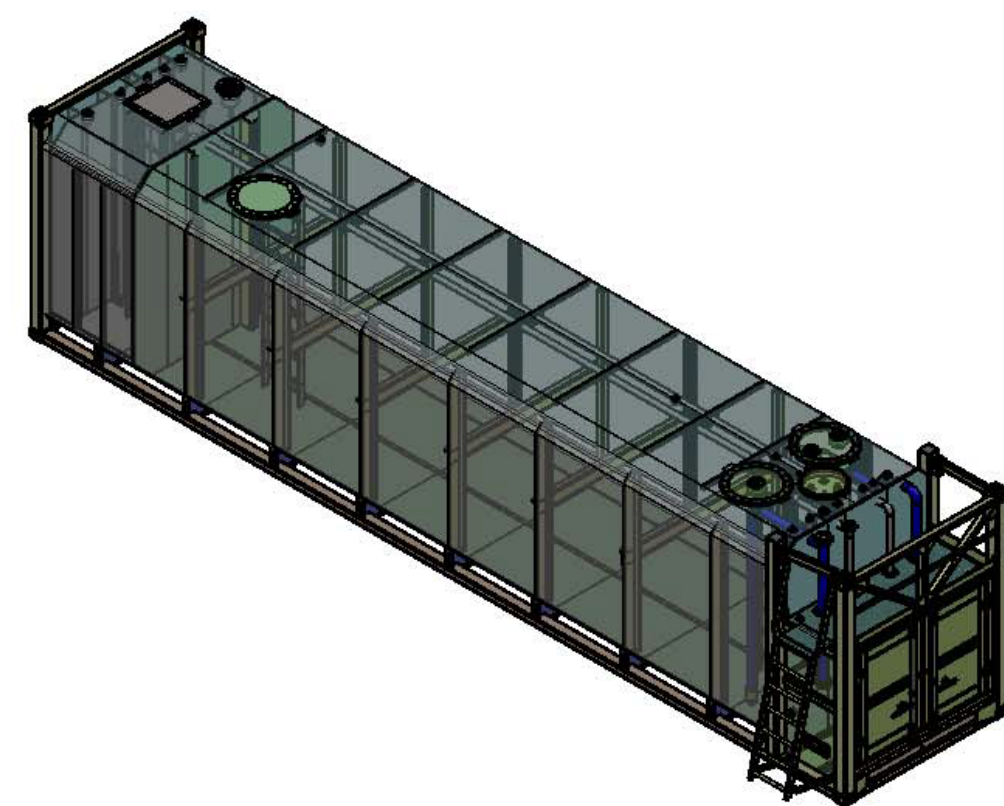
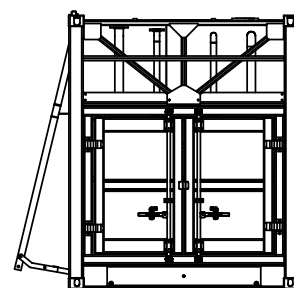
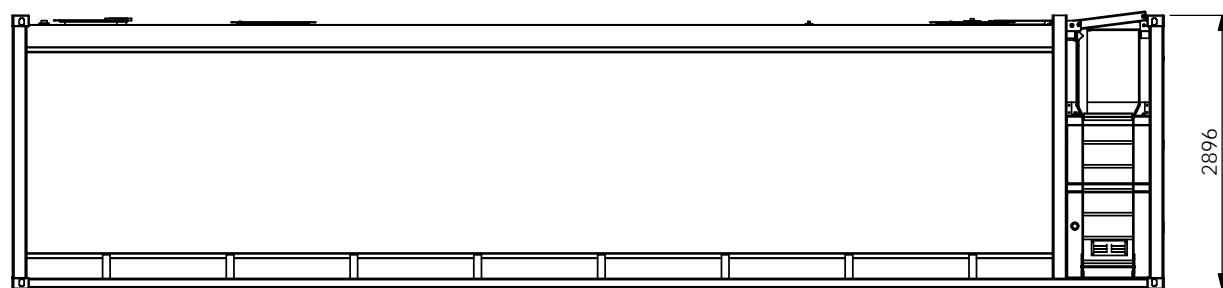
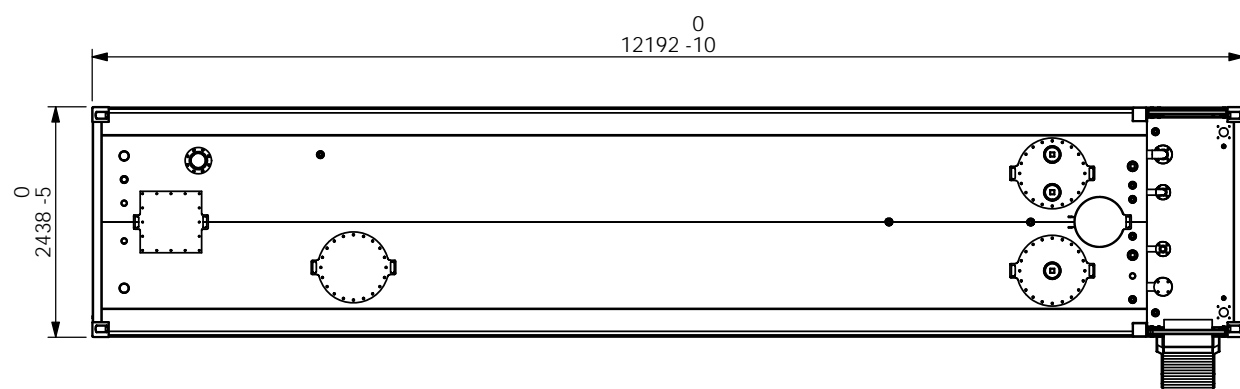

THIRD ANGLE PROJECTION	
○	
NAME	DATE
DRAWN	2016/6/24
CHK'D	
APP'VD	



TOLERANCE U.N.O.
 0 = -1.0
 0.0 = -0.4
 0.00 = -0.1

MATERIAL:
 WEIGHT: 14014.88 Kg

DWG NO. / PART NO.		JOB NO.	
CLIENT: 68,000L GO CON-AB SELF BUNDED TANK			
TITLE:			SHEET SIZE A3
SCALE: N.T.S.		SHEET 1 OF 2	
			REVISION 01

DO NOT SCALE FROM DRAWING. IF IN DOUBT: ASK

UNLESS OTHERWISE SPECIFIED, ALL DIMENSIONS ARE IN MILLIMETRES

BEWARE OF 100mm MEASURING ERROR

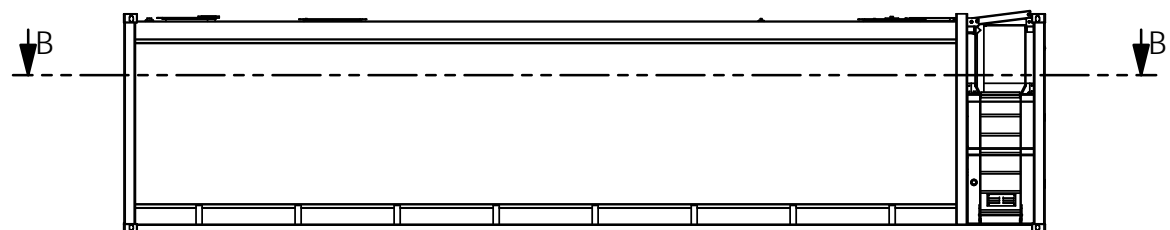
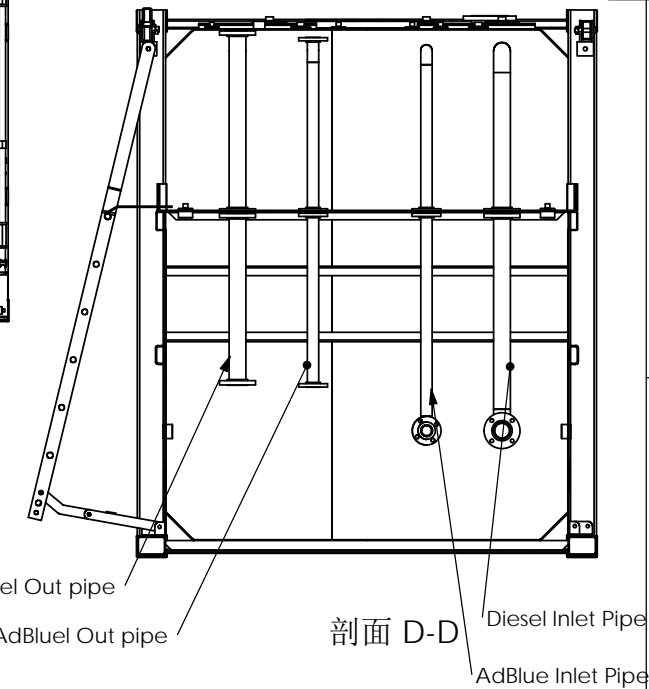
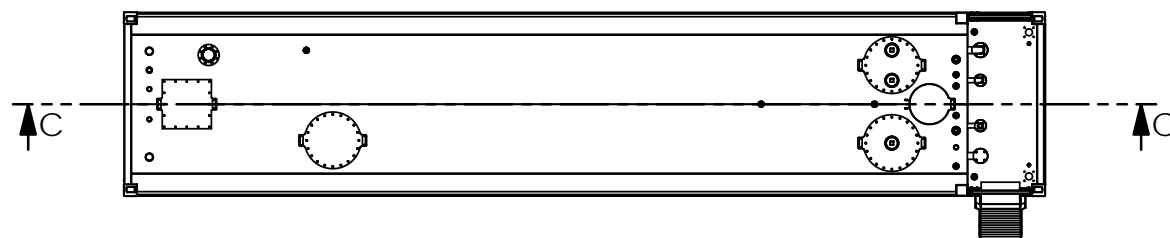
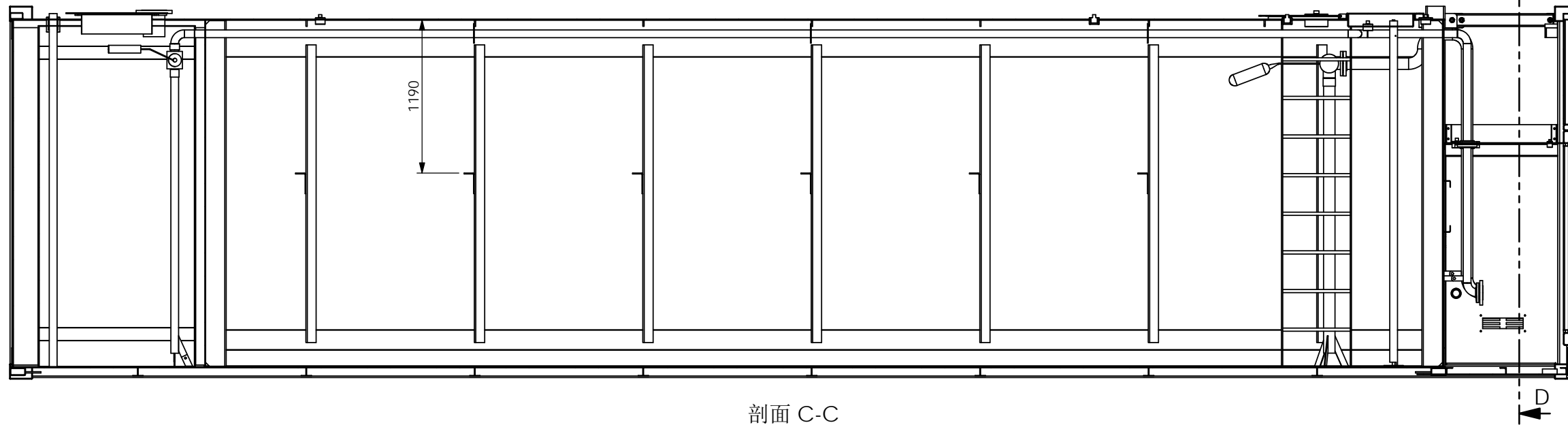
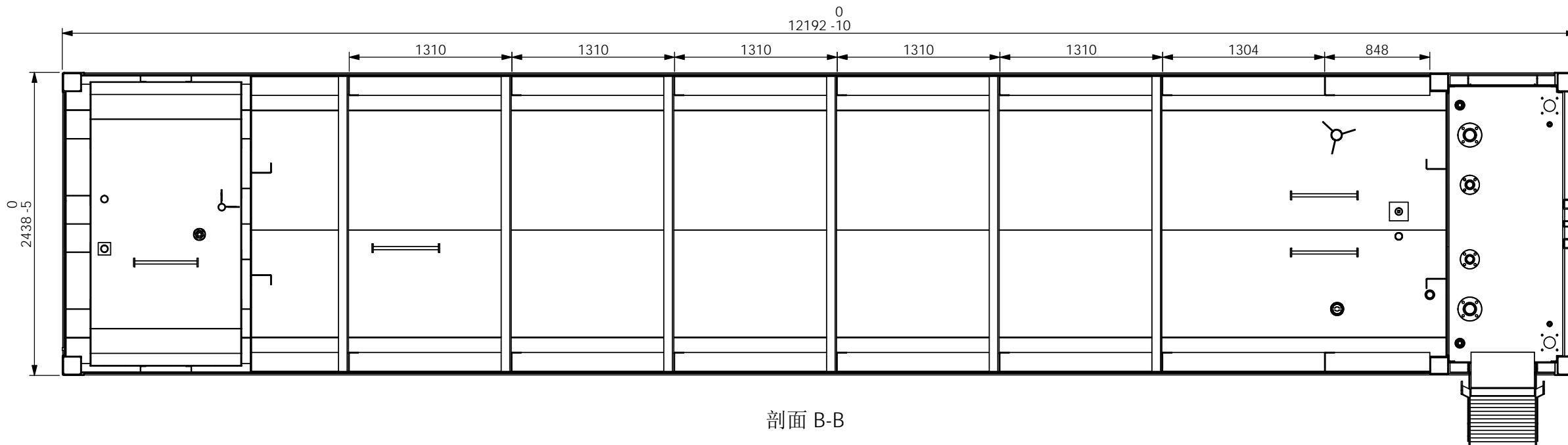

THIRD ANGLE PROJECTION		 goind.com.au
DRAWN	2016/6/24	
CHK'D		
APP'VD		

TOLERANCE U.N.O.
 0 = -1.0
 0.0 = -0.4
 0.00 = -0.1

MATERIAL:
 WEIGHT: 14014.88 Kg

DWG NO. / PART NO.	JOB NO.
CLIENT: 68,000L GO CON-AB SELF BUNDED TANK	
TITLE:	
SCALE: N.T.S.	SHEET 2 OF 2
SHEET SIZE A3	
REVISION 01	