

| Tank | |
|---------------------------|-------------------|
| TANK CONTENTS | |
| DESIGNED TO | AS1940 / AS1692 |
| BUILT TO | AS1657 / AS1554.1 |
| PLATE THICKNESS, Material | 4/4 mm, Q235B |
| Pressue Test | 35KPA |
| External size | 2966x2294x1270mm |
| Internal size | 2858x2186x1058mm |
| GROSS VOLUME | 6600L |
| SAFE FILL LEVEL | 6000L |
| N. D. T. | Require By Client |
| TOTAL MASS | 1823.18KG |

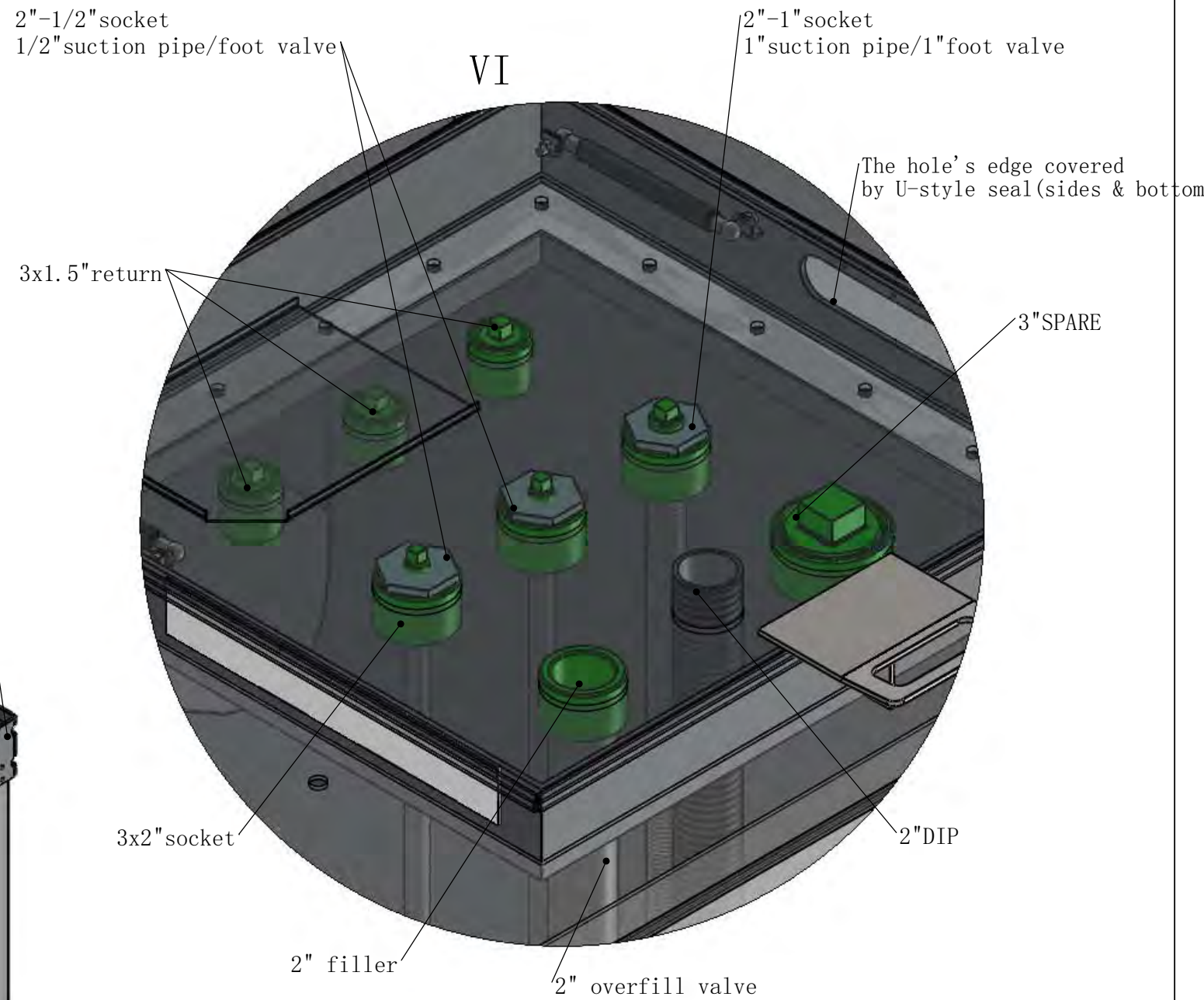

| | | | | | |
|------|-------|-----------|--------|----------|-----------|
| 07 | | | | | |
| 06 | | | | | |
| 05 | | | | | |
| 04 | | | | | |
| 03 | | | | | |
| 02 | | | | | |
| 01 | | | | | |
| REV: | DATE: | REVISION: | DRAWN: | CHECKED: | APPROVED: |

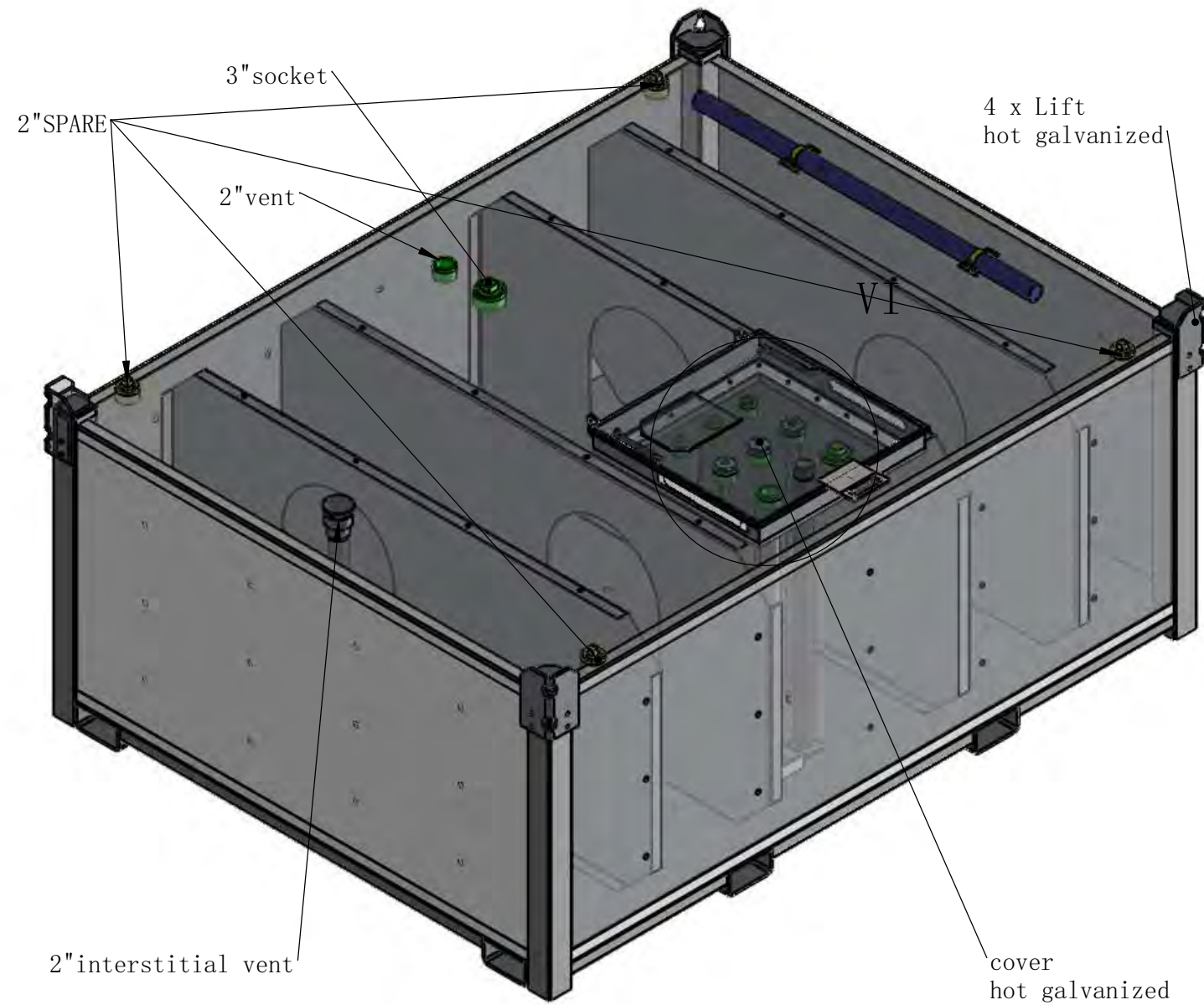

| | | | |
|-----------|------------|----------------------------|----------|
| DRAWN: | DATE: | TITLE: | |
| | 2020-07-02 | BOX 6600L Self Bunded Tank | |
| CHECKED: | DATE: | DRAWING NO. : | REV: |
| | | | 01 |
| CLIENT: | DATE: | | SHEET: |
| | | | 1 of 4 |
| APPROVED: | DATE: | PURCHASE ORDER NO. : | Scale: |
| | | | No scale |
| Material: | | | A3 |
| Weight: | 1823.18KG | | |

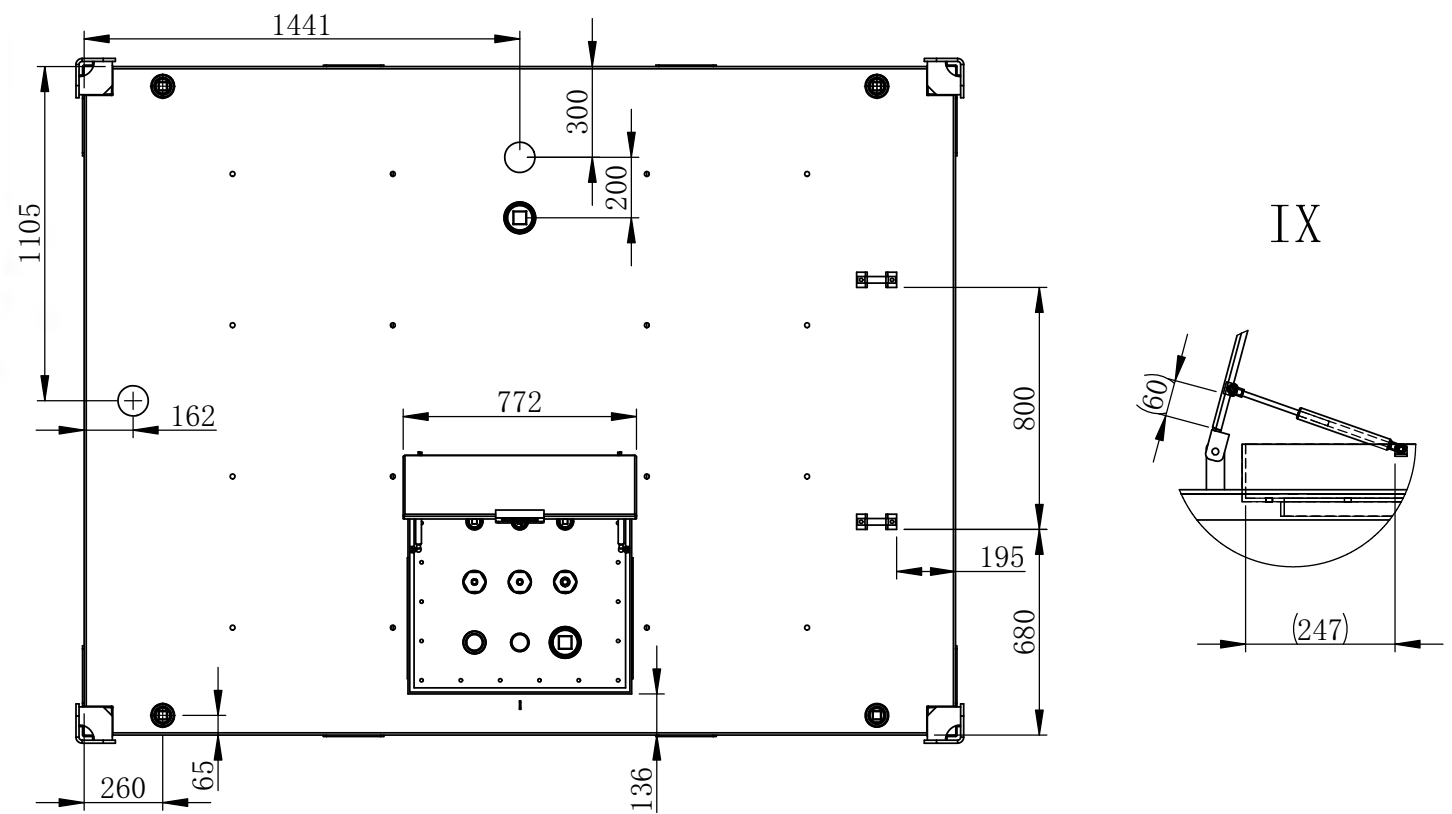
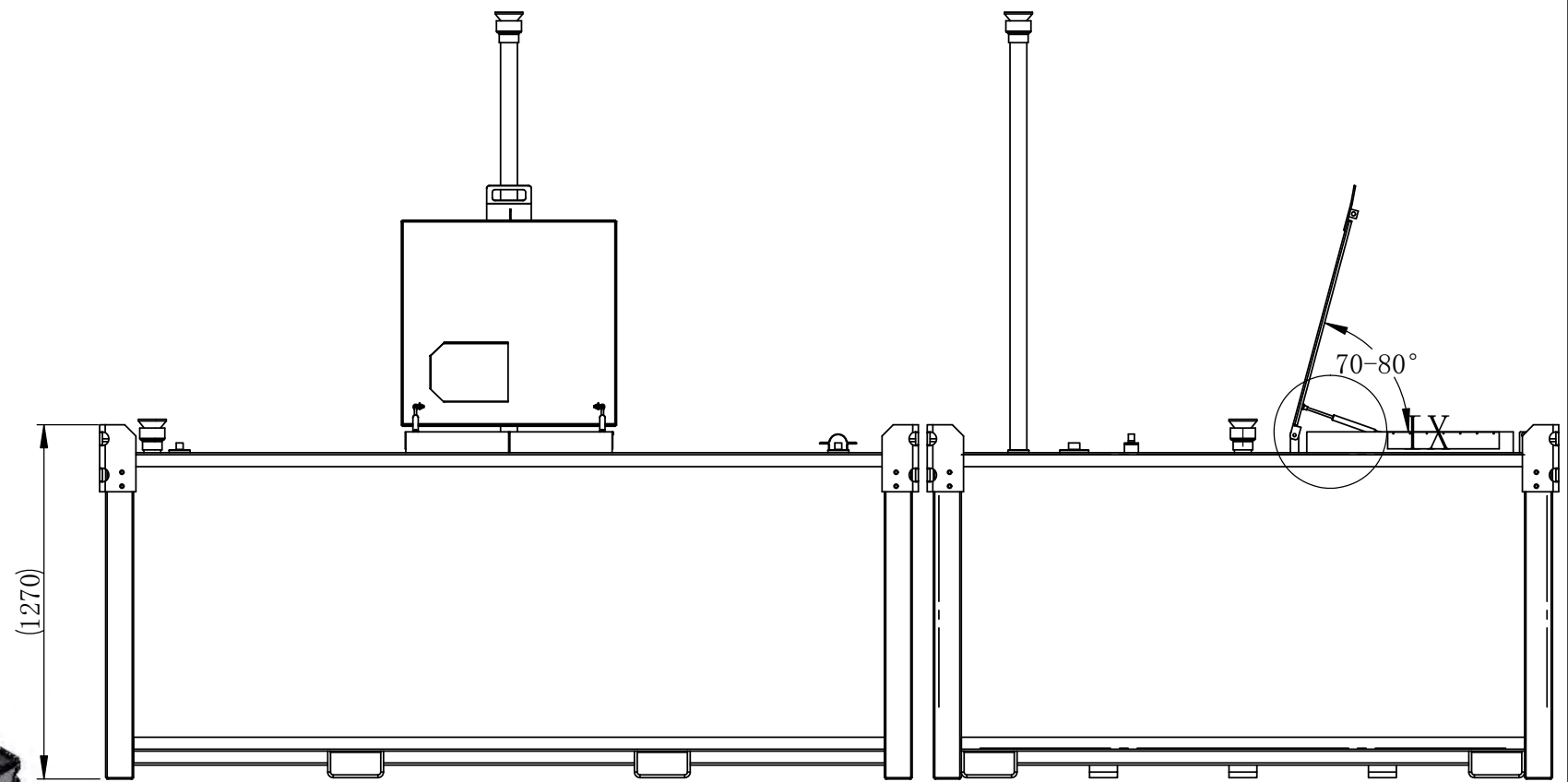
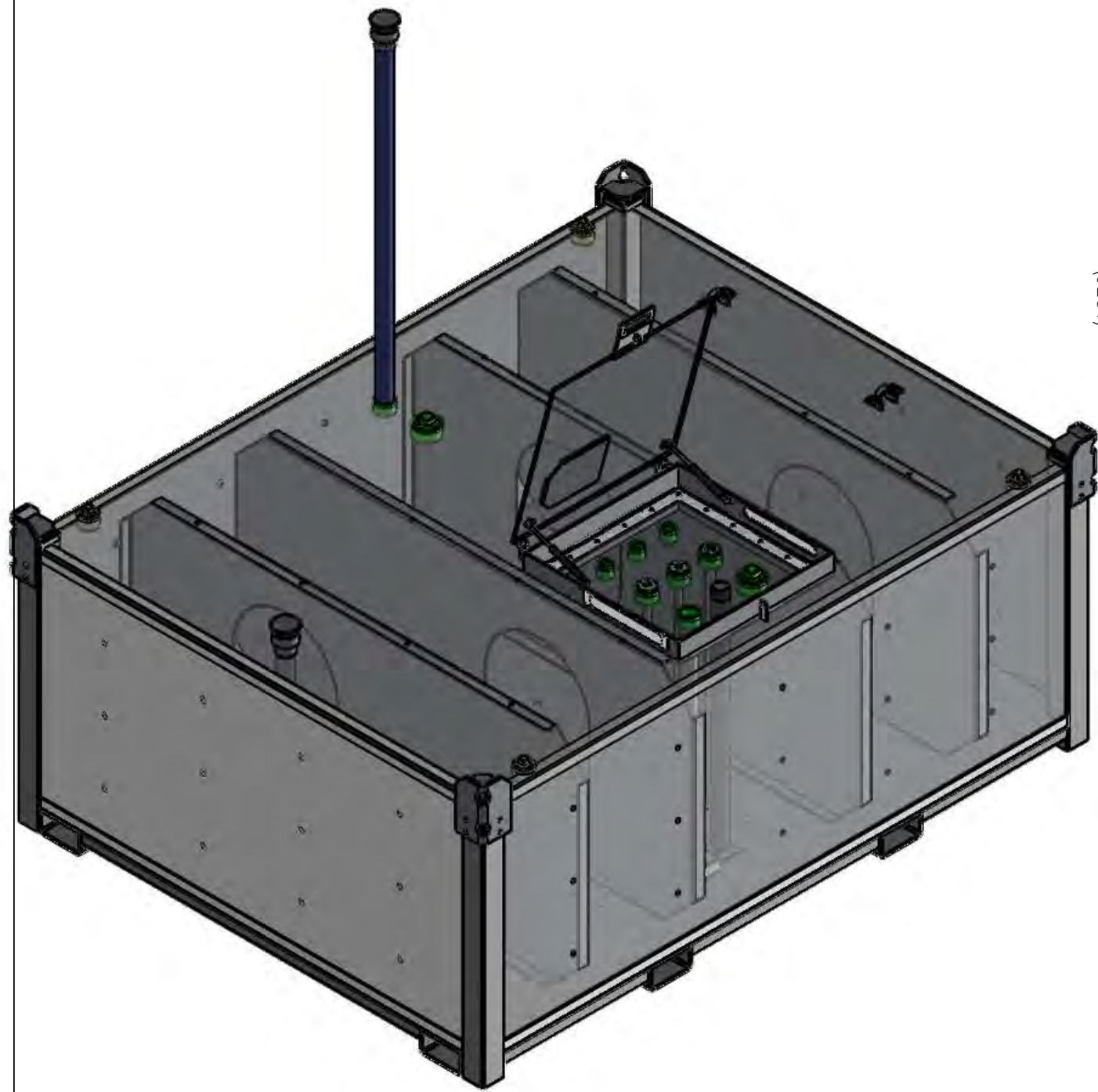

| | | | | | |
|------|-------|-----------|--------|----------|-----------|
| 07 | | | | | |
| 06 | | | | | |
| 05 | | | | | |
| 04 | | | | | |
| 03 | | | | | |
| 02 | | | | | |
| 01 | | | | | |
| REV: | DATE: | REVISION: | DRAWN: | CHECKED: | APPROVED: |



| | | | | | |
|-----------|-----------|-----------|-------|--------------------------------------|------------------|
| | | DRAWN: | DATE: | TITLE: BOX 6600L Self Bunded Tank | |
| | | CHECKED: | DATE: | | |
| | | CLIENT: | DATE: | DRAWING NO. : | REV: 01 |
| | | APPROVED: | DATE: | | SHEET: 2 of 4 |
| Material: | | | | PURCHASE | Scale: |
| Weight: | 1823.18KG | | | ORDER NO. : | No scale |

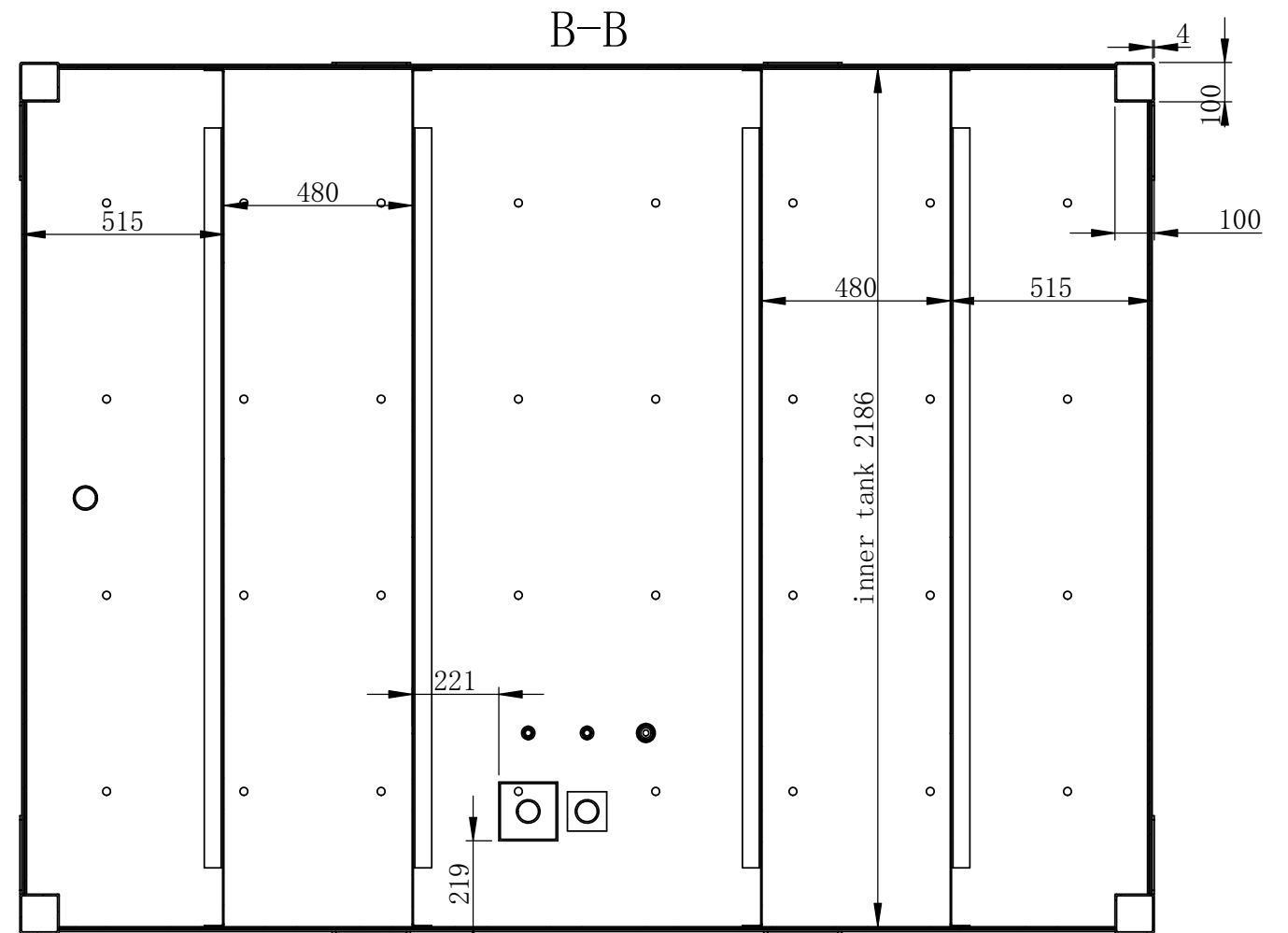
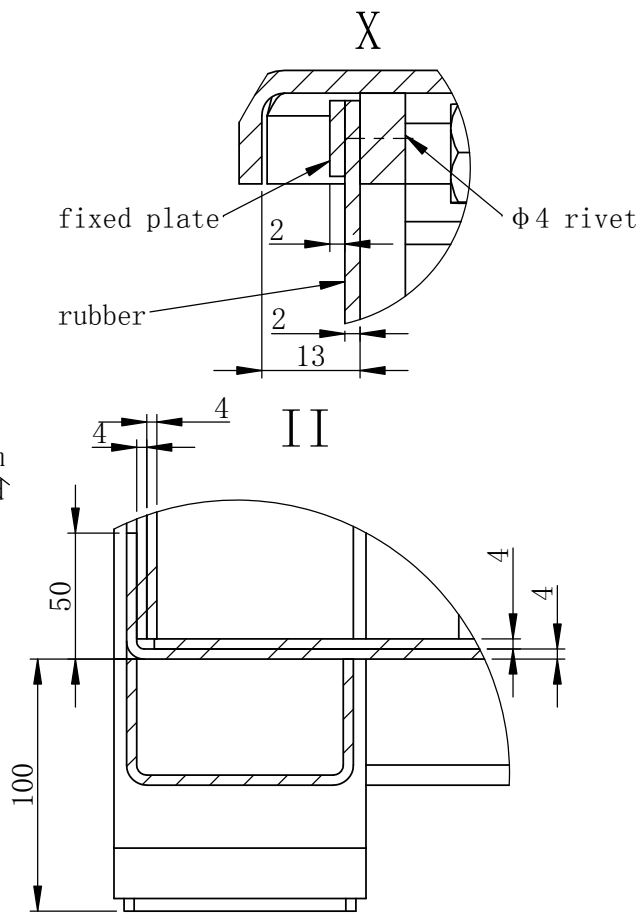
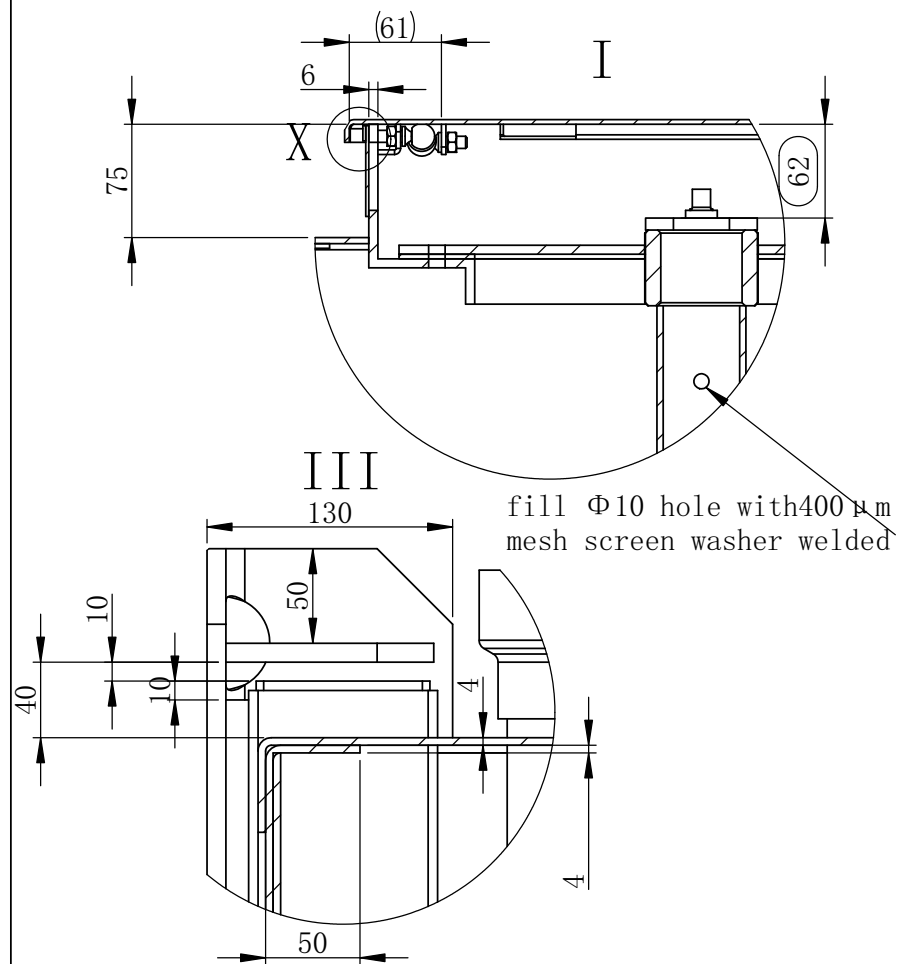
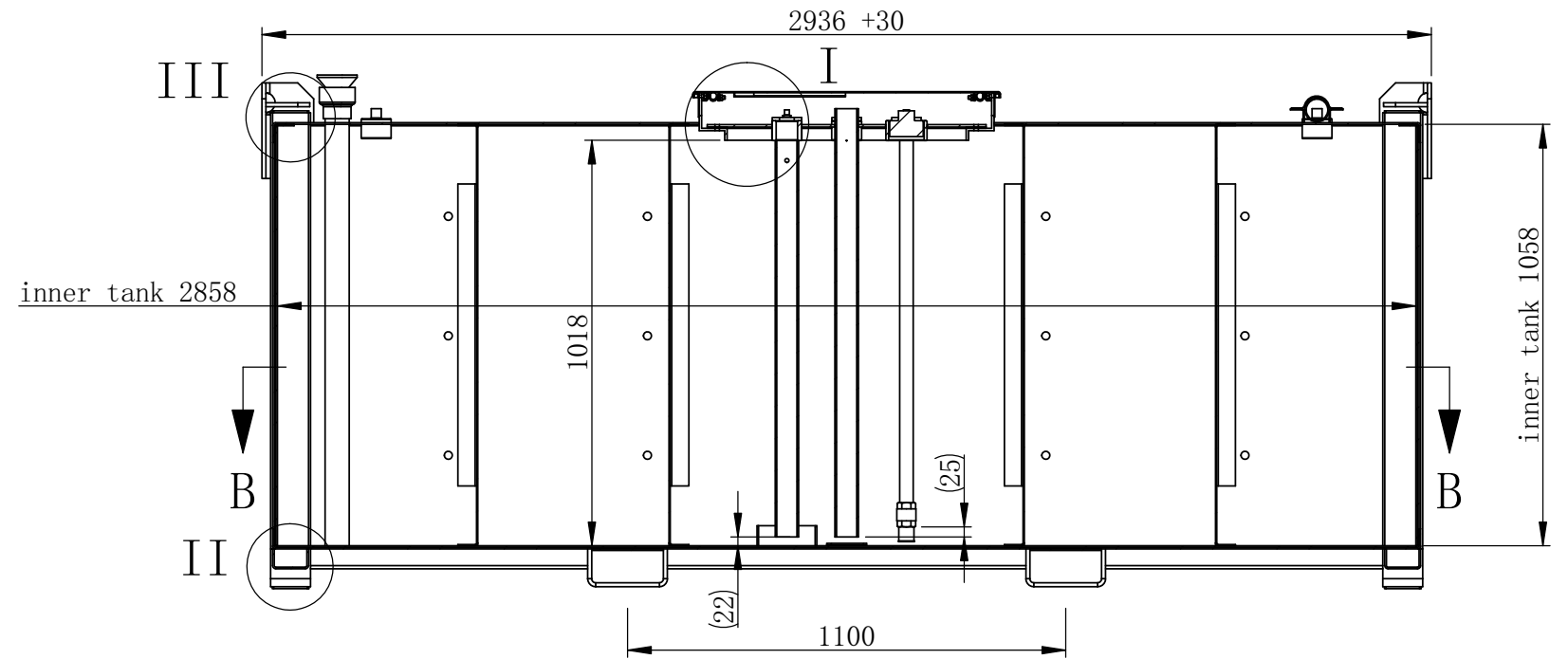
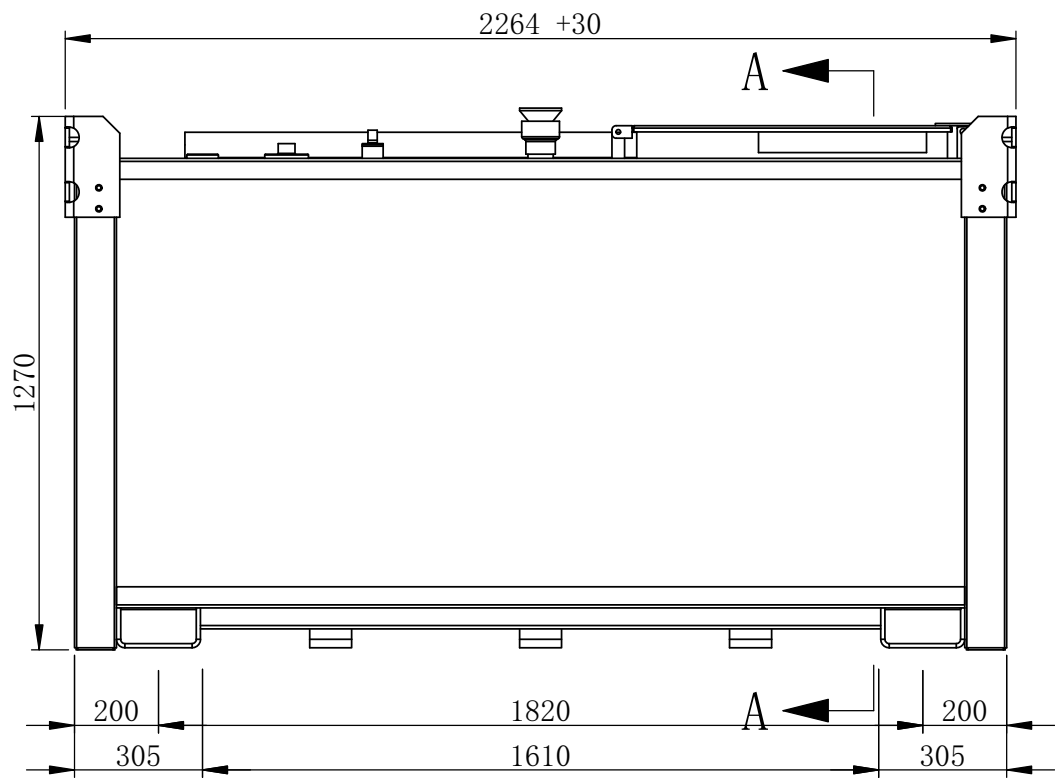

| | | | | | |
|------|-------|-----------|--------|----------|-----------|
| 07 | | | | | |
| 06 | | | | | |
| 05 | | | | | |
| 04 | | | | | |
| 03 | | | | | |
| 02 | | | | | |
| 01 | | | | | |
| REV: | DATE: | REVISION: | DRAWN: | CHECKED: | APPROVED: |



| | |
|-----------|-----------|
| Material: | |
| Weight: | 1823.18KG |

| | |
|-----------|-------|
| DRAWN: | DATE: |
| CHECKED: | DATE: |
| CLIENT: | DATE: |
| APPROVED: | DATE: |

| | | | |
|----------------------------|--|----------|--------|
| TITLE: | | REV: | A3 |
| BOX 6600L Self Bunded Tank | | | |
| DRAWING NO. : | | SHEET: | Scale: |
| | | 3 of 4 | |
| PURCHASE ORDER NO. : | | No scale | |

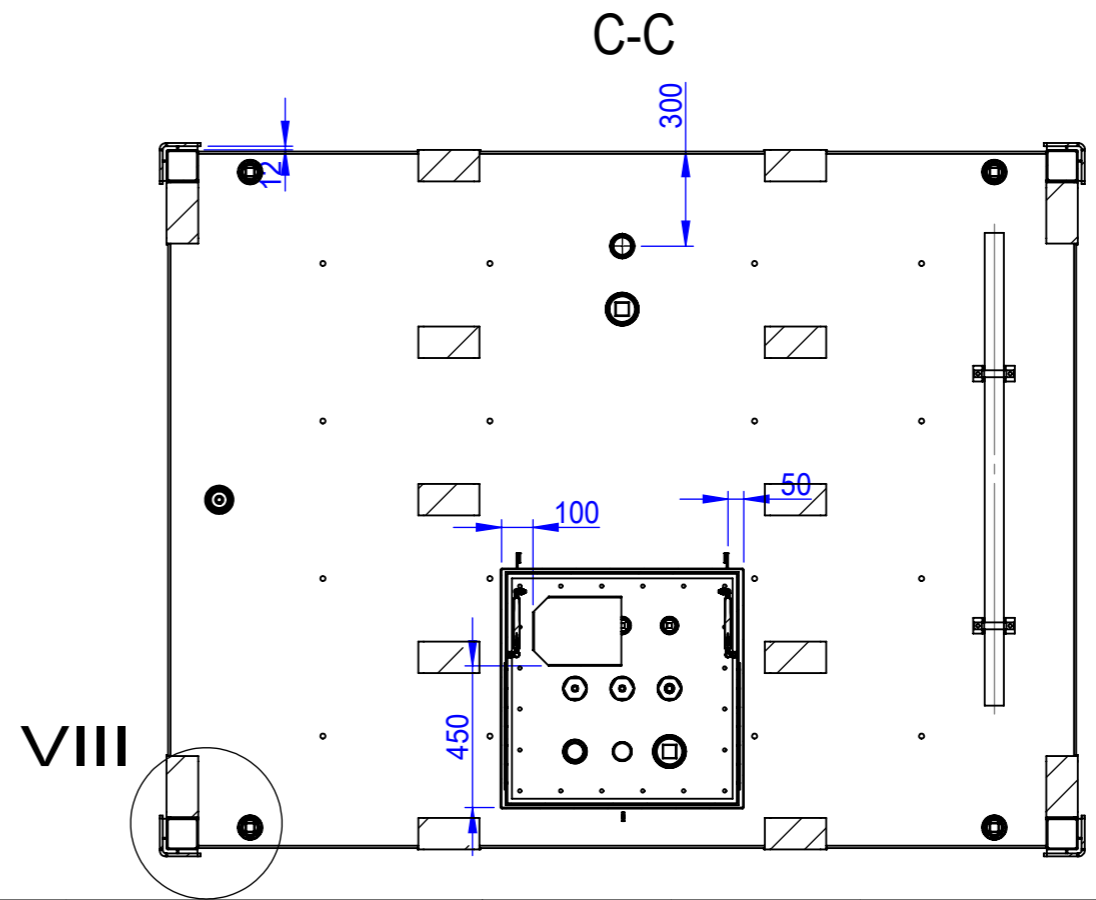
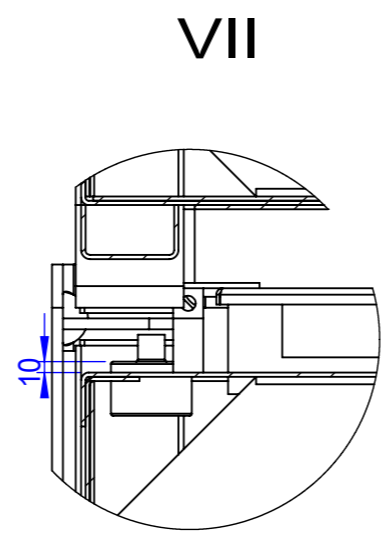
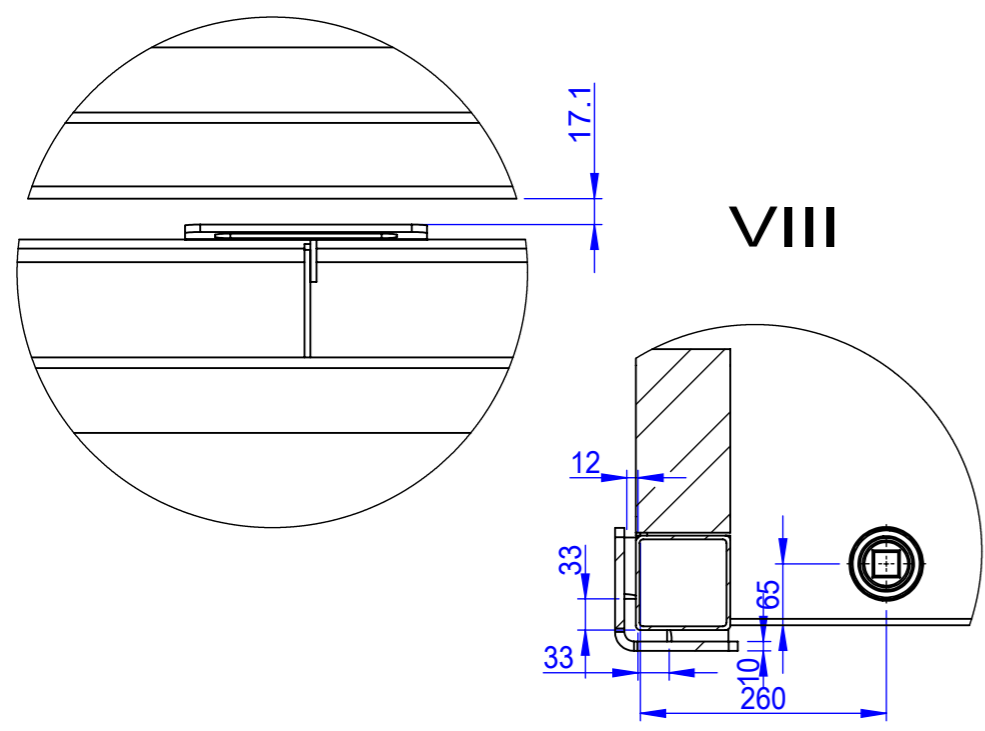
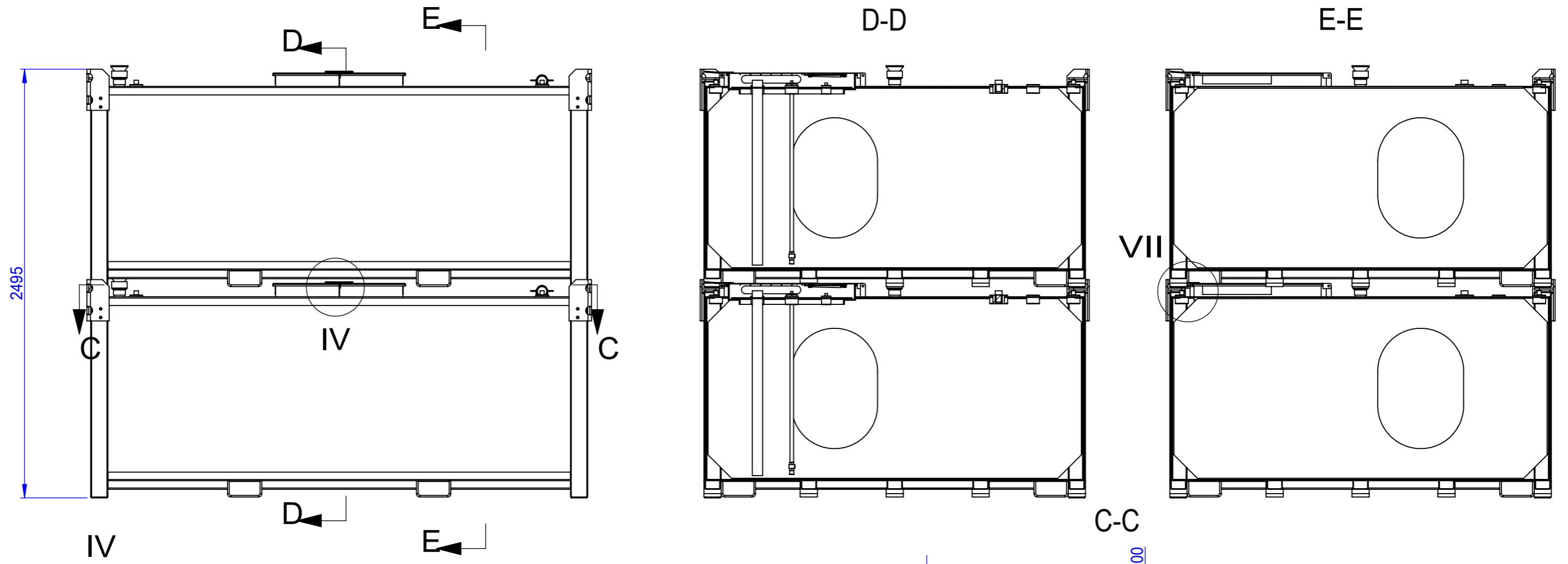

| | | | | | |
|------|-------|-----------|--------|----------|-----------|
| 07 | | | | | |
| 06 | | | | | |
| 05 | | | | | |
| 04 | | | | | |
| 03 | | | | | |
| 02 | | | | | |
| 01 | | | | | |
| REV: | DATE: | REVISION: | DRAWN: | CHECKED: | APPROVED: |



| | | | |
|-----------|-----------|--------------------------------------|----------|
| DRAWN: | DATE: | TITLE: BOX 6600L Self Bunded Tank | |
| | 2020/5/15 | | |
| CHECKED: | DATE: | DRAWING NO. : | REV: |
| CLIENT: | DATE: | | 01 |
| APPROVED: | DATE: | PURCHASE ORDER NO. : | SHEET: |
| | | | 4 of 4 |
| Material: | | | Scale: |
| Weight: | 3642.81KG | | No scale |

A3

