

DO NOT SCALE FROM DRAWING. IF IN DOUBT: ASK

UNLESS OTHERWISE SPECIFIED, ALL DIMENSIONS ARE IN MILLIMETRES

BEWARE OF 100mm MEASURING ERROR

TANK DATA	
TANK CONTENTS:	ADBLUE
DESIGNED TO:	AS1940
BUILT TO:	AS1692
CORROSION ALLOW.	0mm
GROSS VOLUME:	12,105L
HYD.TEST PRESSURE:	21KPa
SAFE FILL LEVEL	11,500L
N.D.T.	Refer fabrication & assembly plan
TOTAL MASS:	3205kg

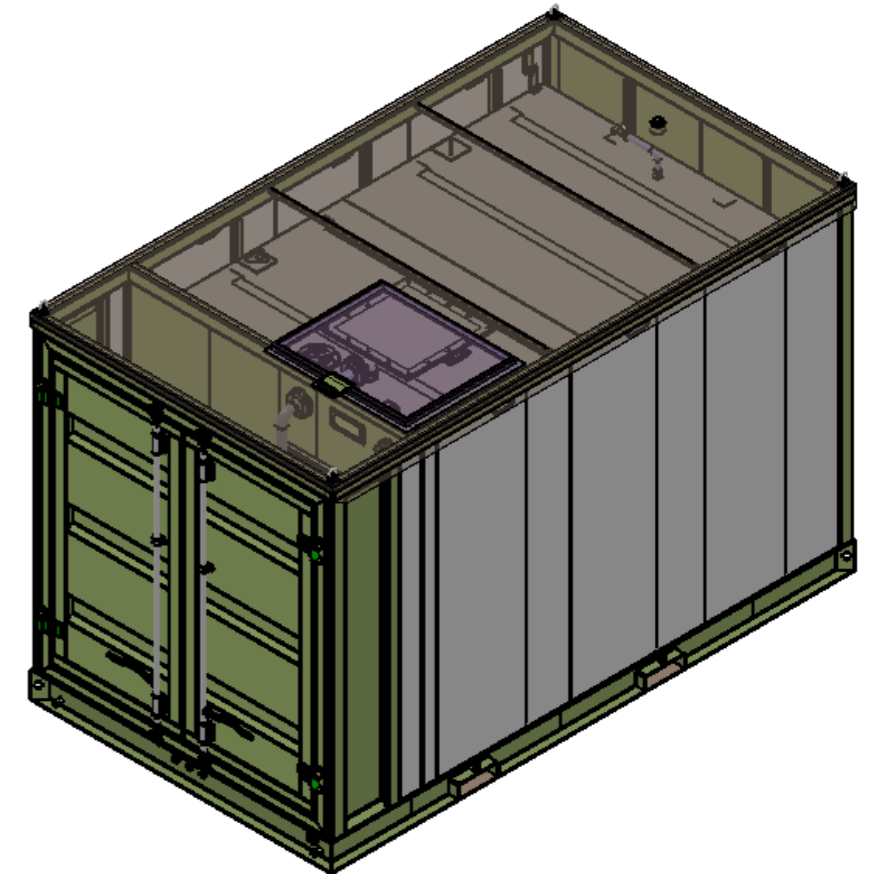
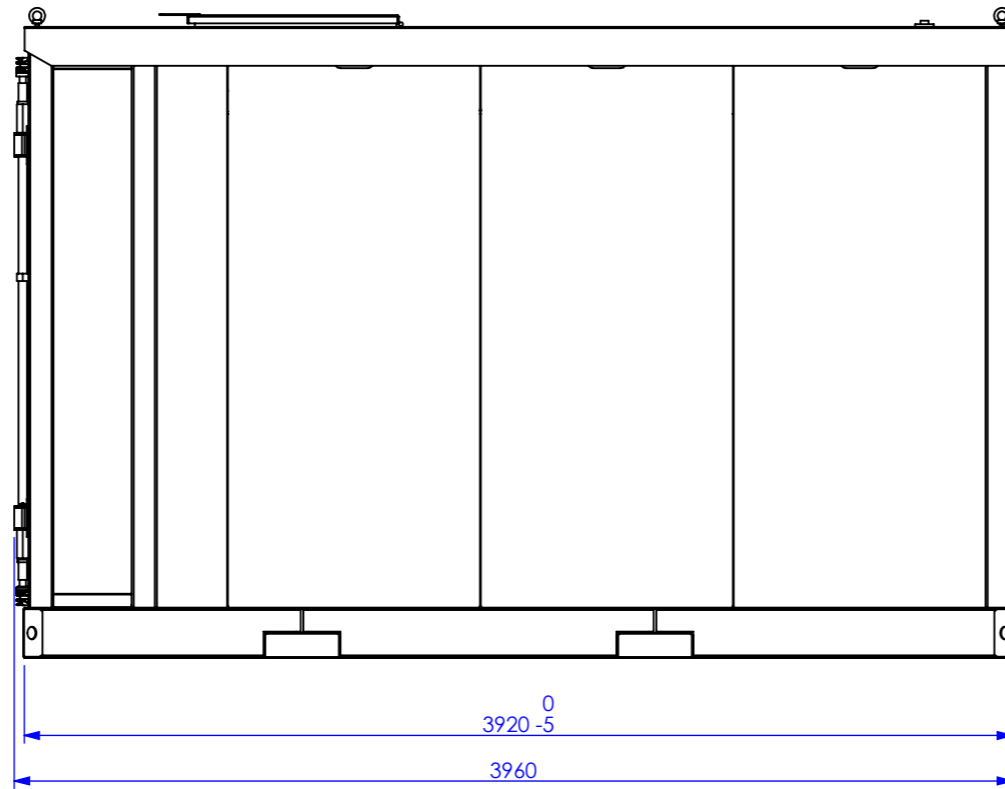
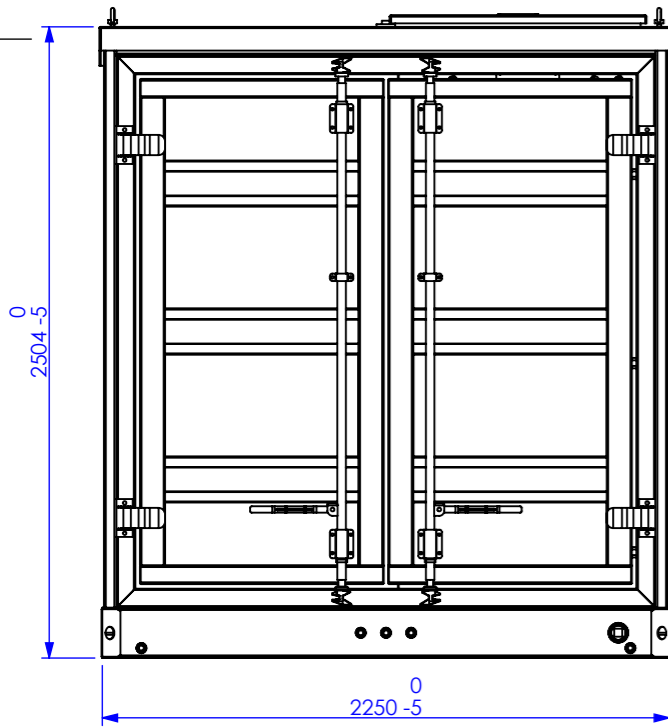
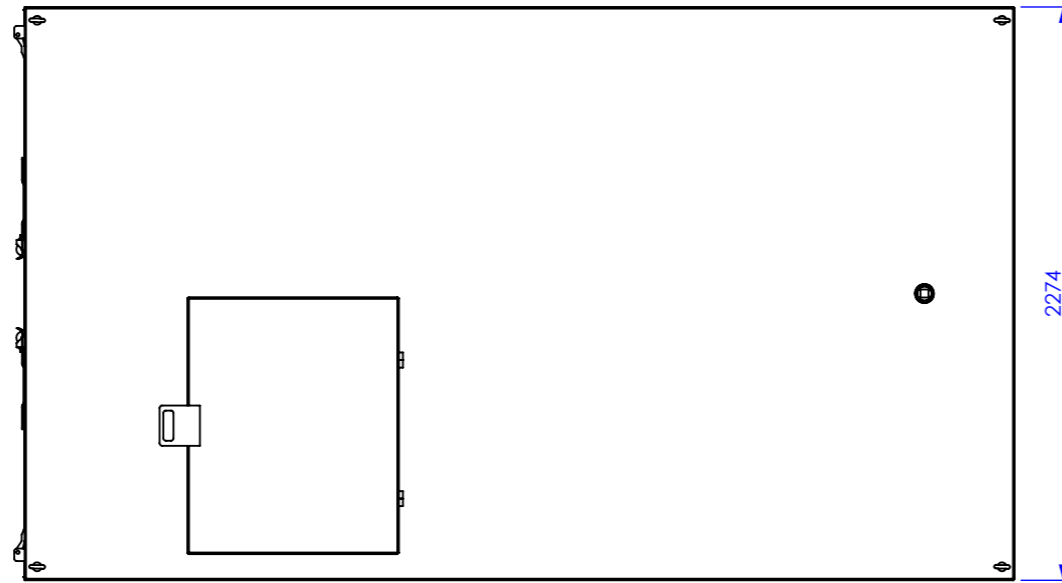

External Tank Material : Q235  
 Adblue Tank Material : SS304

THIRD ANGLE PROJECTION	
NAME	DATE
DRAWN	2015/6/19
CHK'D	
APPV'D	



TOLERANCE U.N.O.  
 0 = -1.0  
 0.0 = -0.4  
 0.00 = -0.1

DWG NO. / PART NO.  
 ADBLUE AB-11 11,000L

JOB NO.

LIQUIP:

TITLE:

SHEET SIZE  
**A3**

REVISION

SCALE: N.T.S.

SHEET 1 OF 3

DO NOT SCALE FROM DRAWING. IF IN DOUBT: ASK

UNLESS OTHERWISE SPECIFIED, ALL DIMENSIONS ARE IN MILLIMETRES

BEWARE OF 100mm MEASURING ERROR

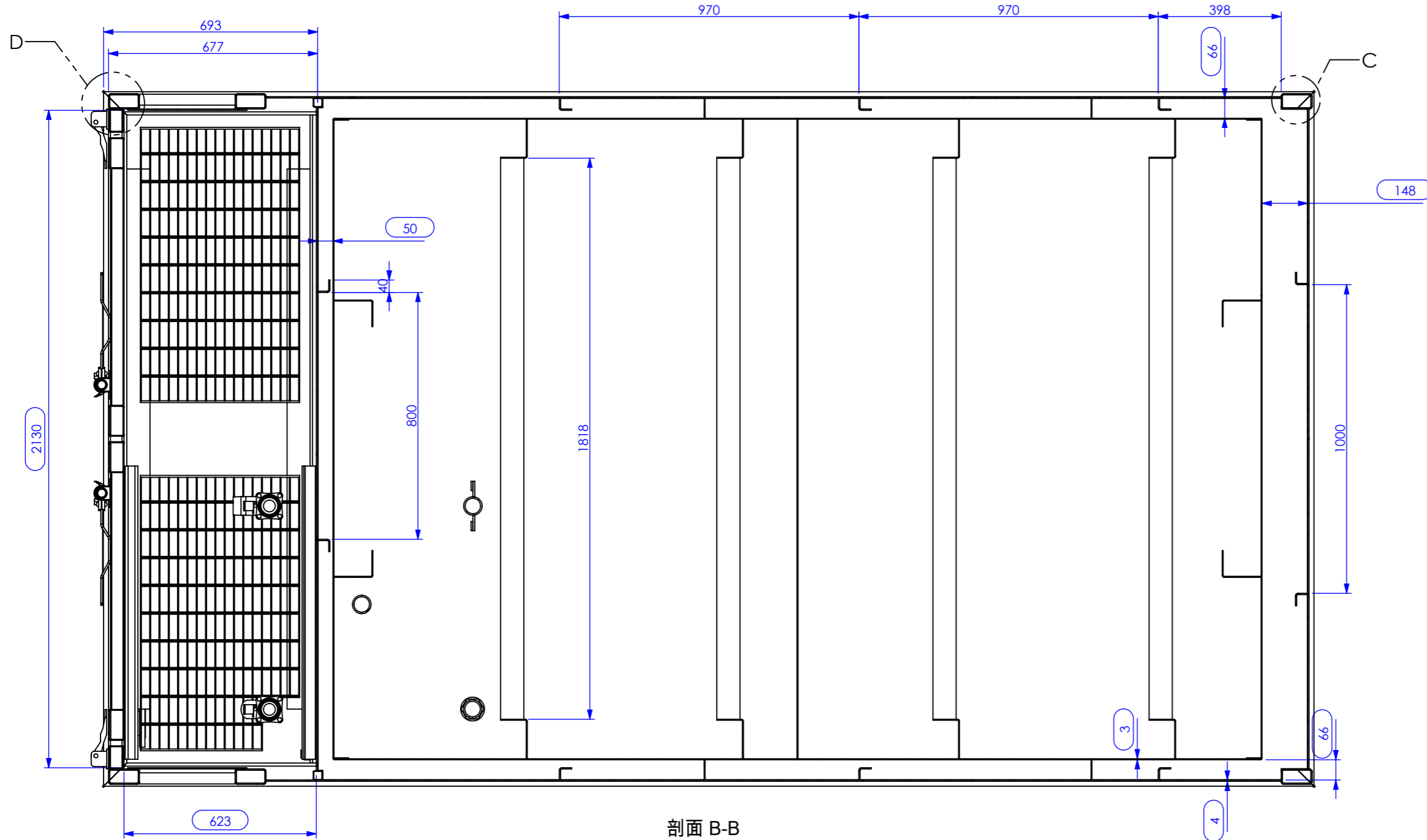

剖面 B-B

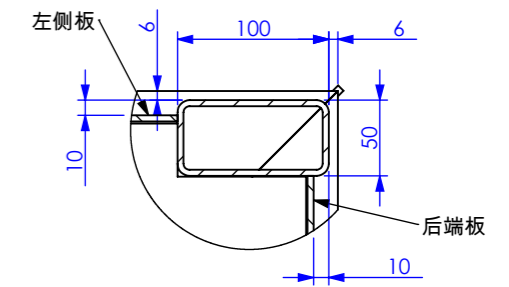

C

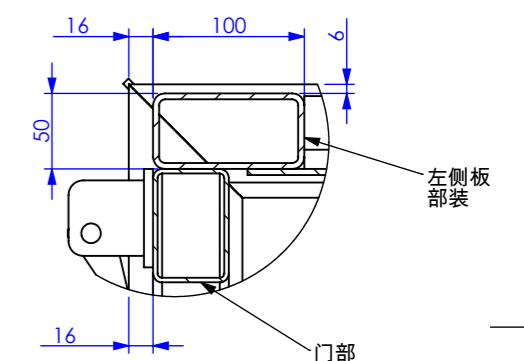

D

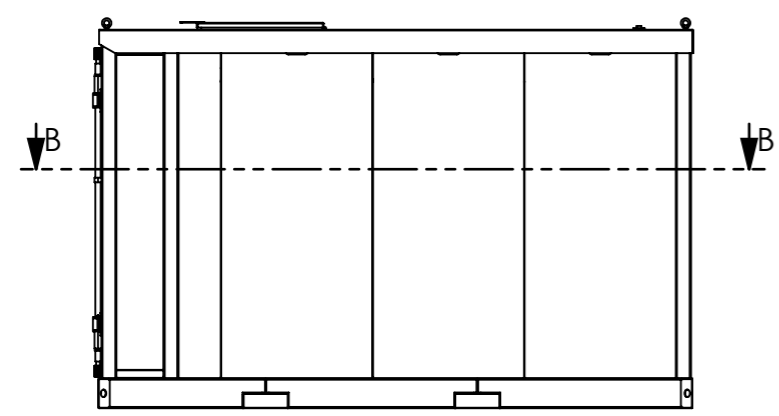

THIRD ANGLE PROJECTION			DWG NO. / PART NO. ADBLUE AB-11 11,000L	JOB NO.
			LIQUIP:	
		TITLE:	SHEET SIZE A3	
		SCALE: N.T.S.	SHEET 2 OF 3	
NAME	DATE	TOLERANCE U.N.O.	REVISION	
DRAWN	2015/6/19	0 = -1.0		
CHK'D		0.0 = -0.4		
APPV'D		0.00 = -0.1		
		MATERIAL:		
		WEIGHT: 3205 Kg		

DO NOT SCALE FROM DRAWING. IF IN DOUBT: ASK

UNLESS OTHERWISE SPECIFIED, ALL DIMENSIONS ARE IN MILLIMETRES

BEWARE OF 100mm MEASURING ERROR

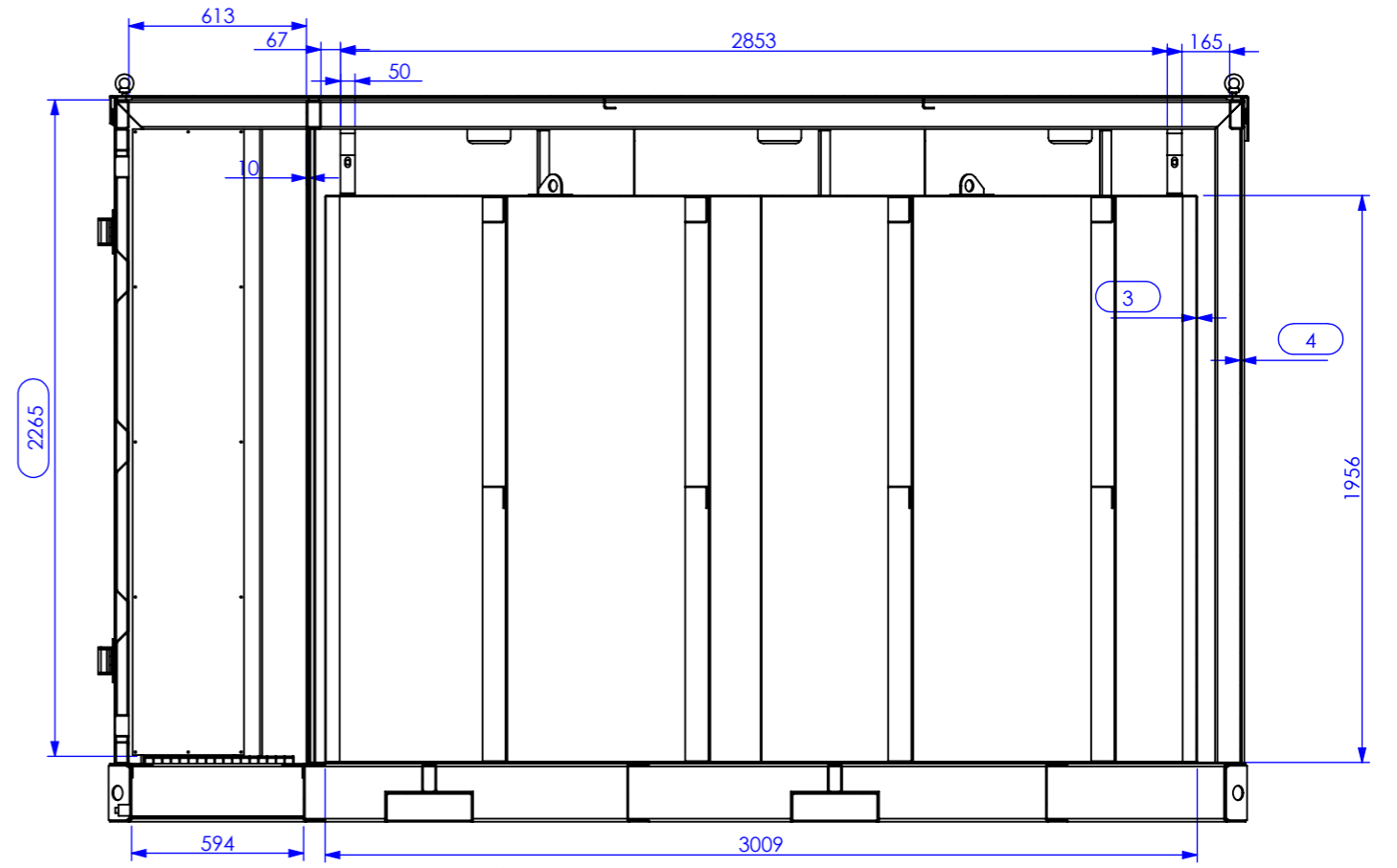
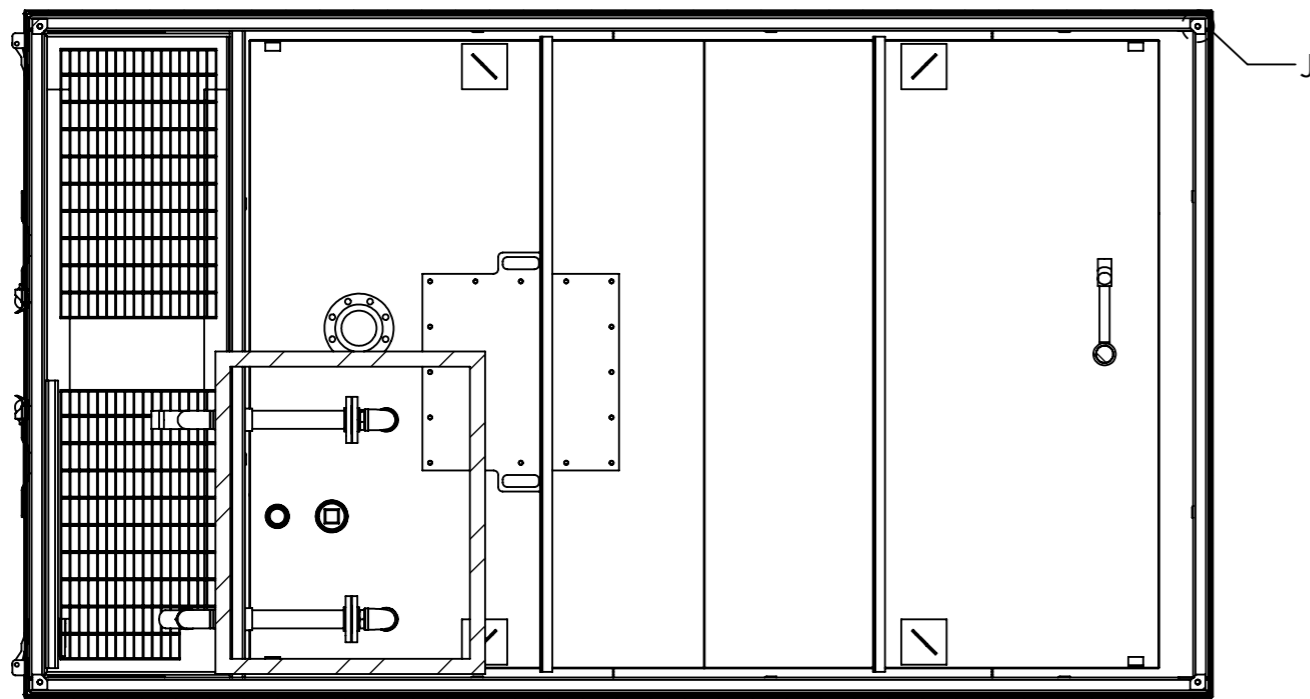

H-H

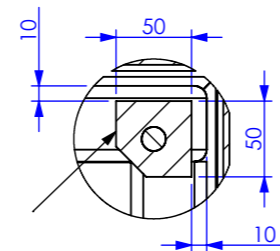
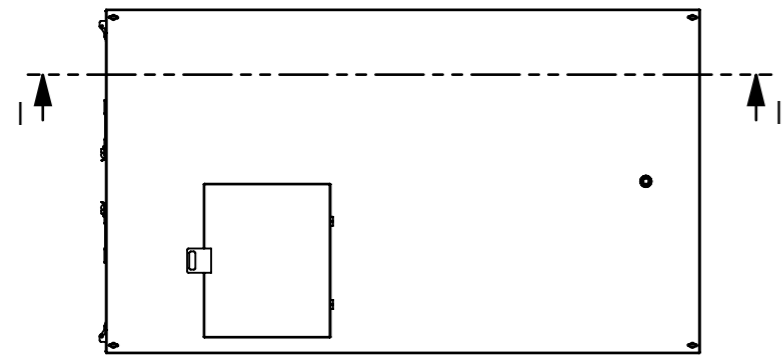

J

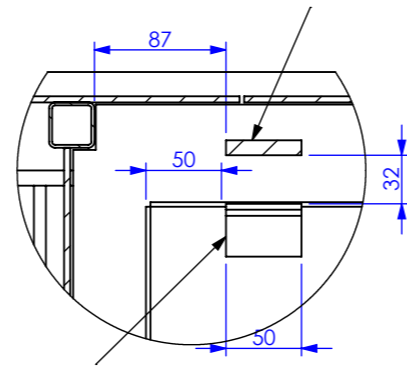

L

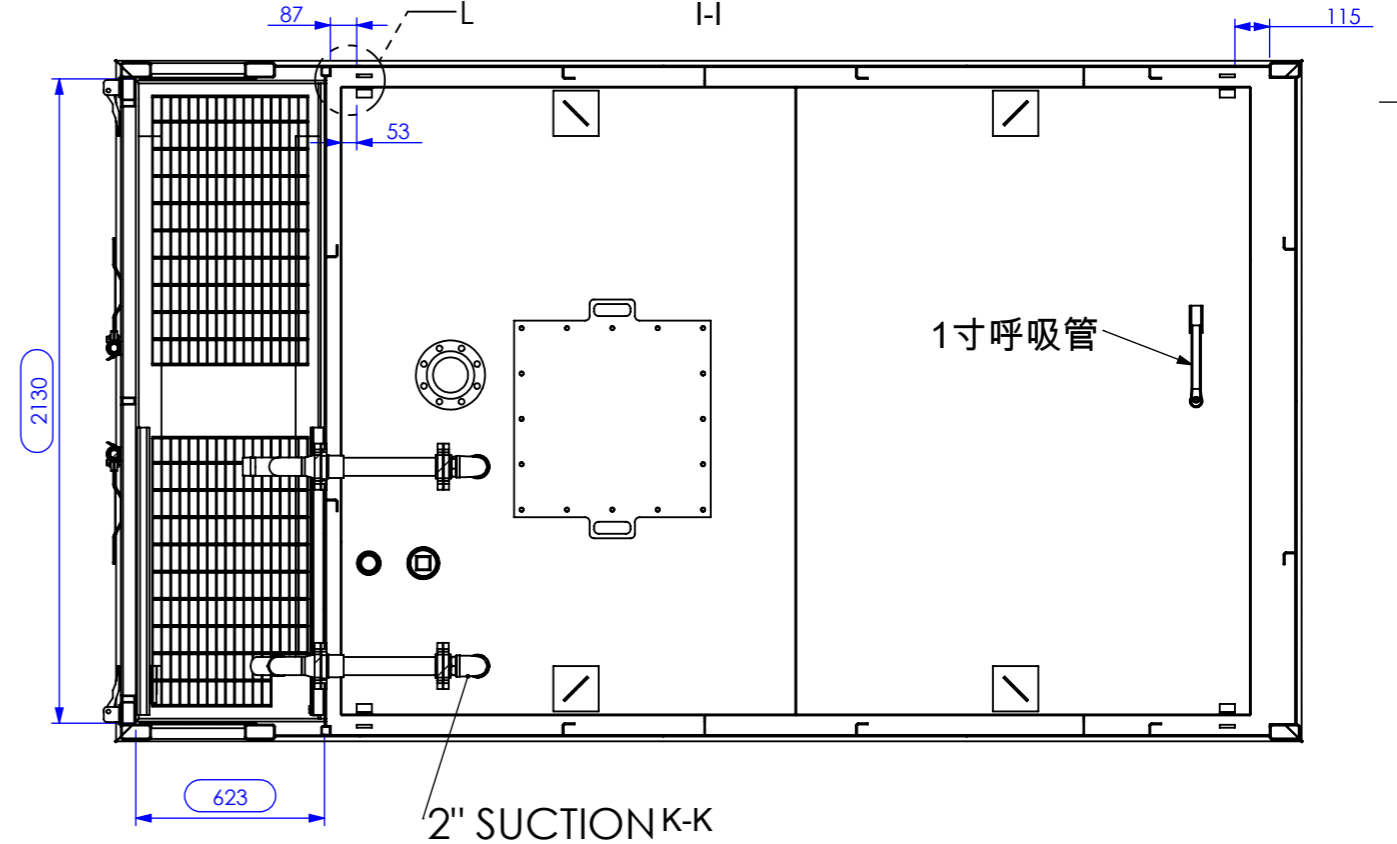
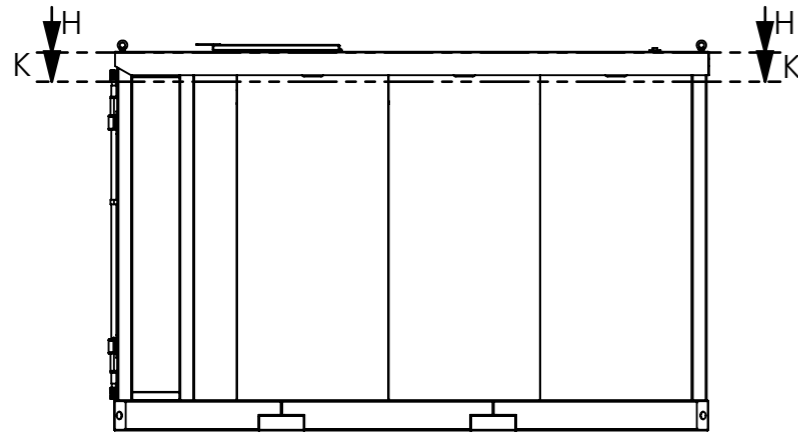

THIRD ANGLE PROJECTION		 goind.com.au		DWG NO. / PART NO. ADBLUE AB-11 11,000L		JOB NO.	
DRAWN				2015/6/19		LIQUIP:	
CHK'D				TOLERANCE U.N.O. 0 = -1.0 0.0 = -0.4 0.00 = -0.1		MATERIAL:	
APPV'D				WEIGHT: 3205 Kg		REVISION	
				SCALE: N.T.S.		SHEET 3 OF 3	

DO NOT SCALE FROM DRAWING. IF IN DOUBT: ASK

UNLESS OTHERWISE SPECIFIED, ALL DIMENSIONS ARE IN MILLIMETRES

BEWARE OF 100mm MEASURING ERROR

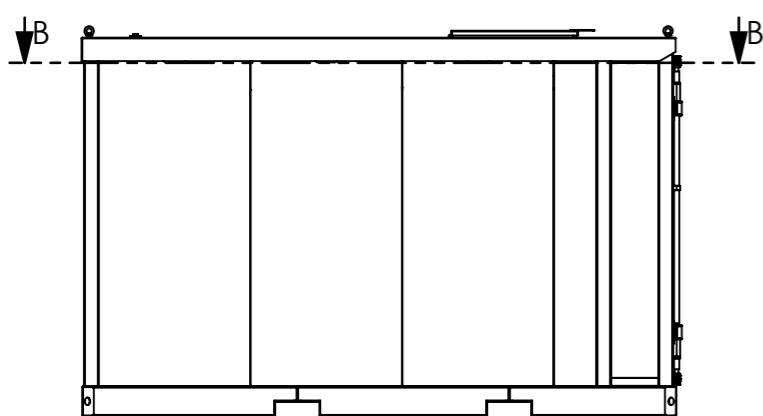
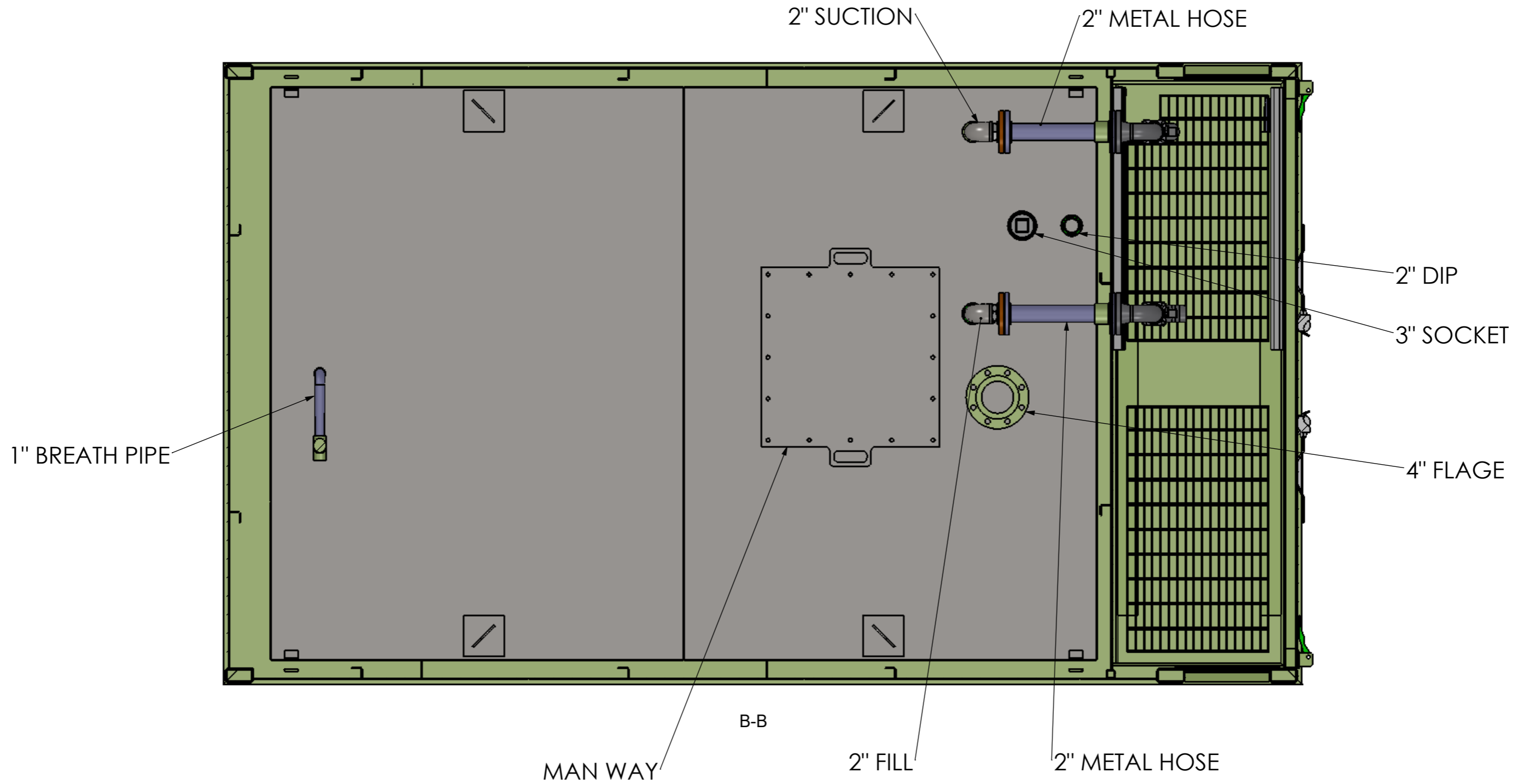

THIRD ANGLE PROJECTION			DWG NO. / PART NO. ADBLUE AB-11 11,000L	JOB NO.
			CLIENT:	
		TITLE:		SHEET SIZE A3
		SCALE: N.T.S.		SHEET 1 OF 2
NAME	DATE	TOLERANCE U.N.O.	REVISION	
DRAWN	2017/8/10	0 = -1.0		
CHK'D		0.0 = -0.4		
APP'V'D		0.00 = -0.1		
		WEIGHT: Kg		

DO NOT SCALE FROM DRAWING. IF IN DOUBT: ASK

UNLESS OTHERWISE SPECIFIED, ALL DIMENSIONS ARE IN MILLIMETRES

BEWARE OF 100mm MEASURING ERROR

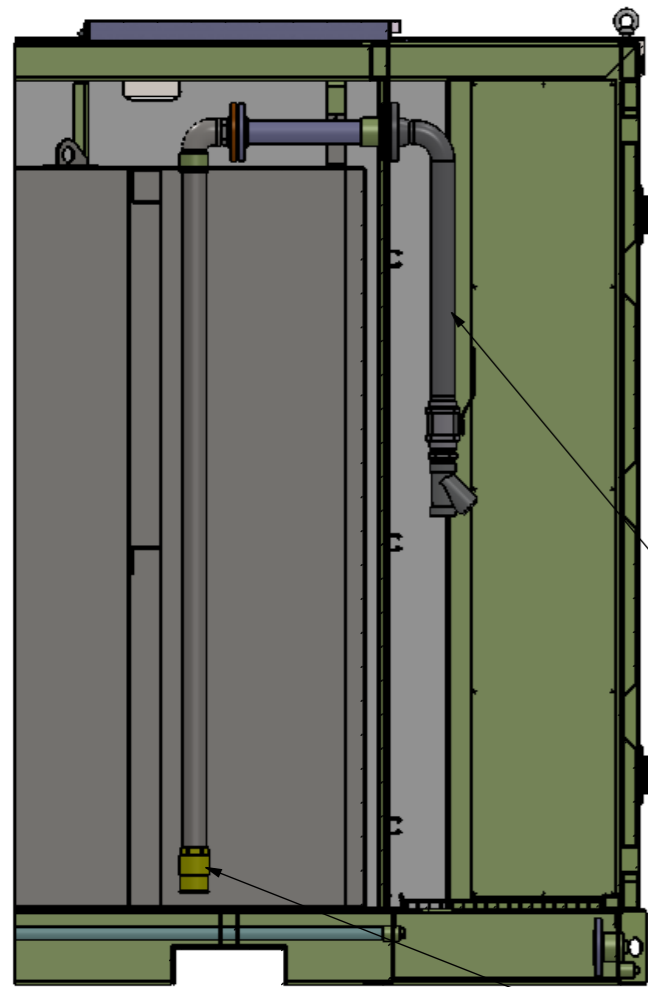

E-E

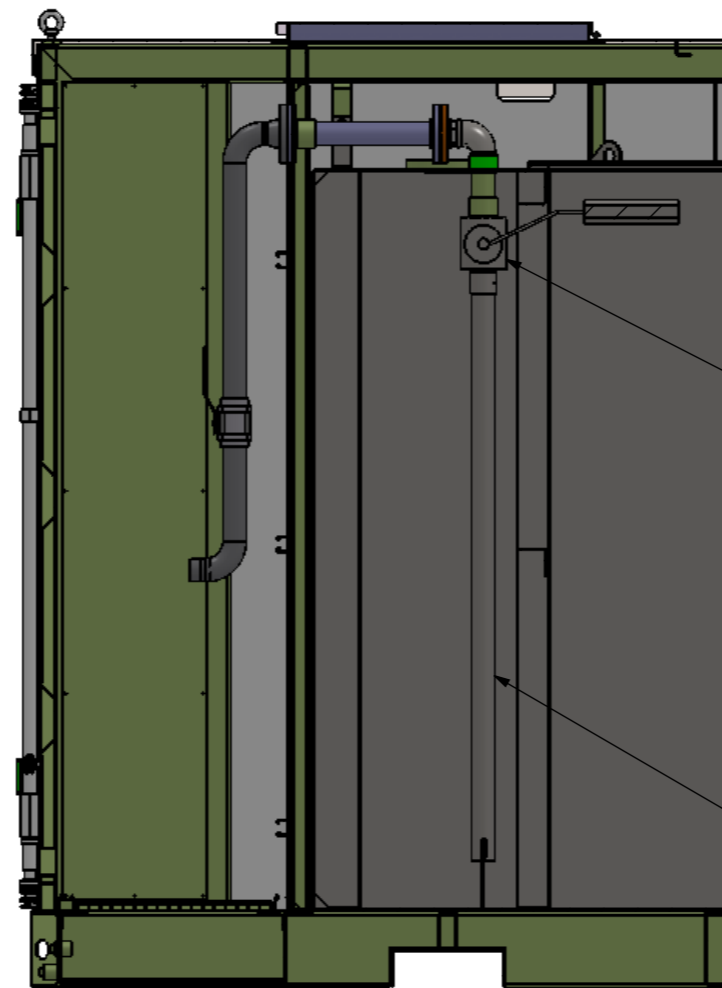

F-F

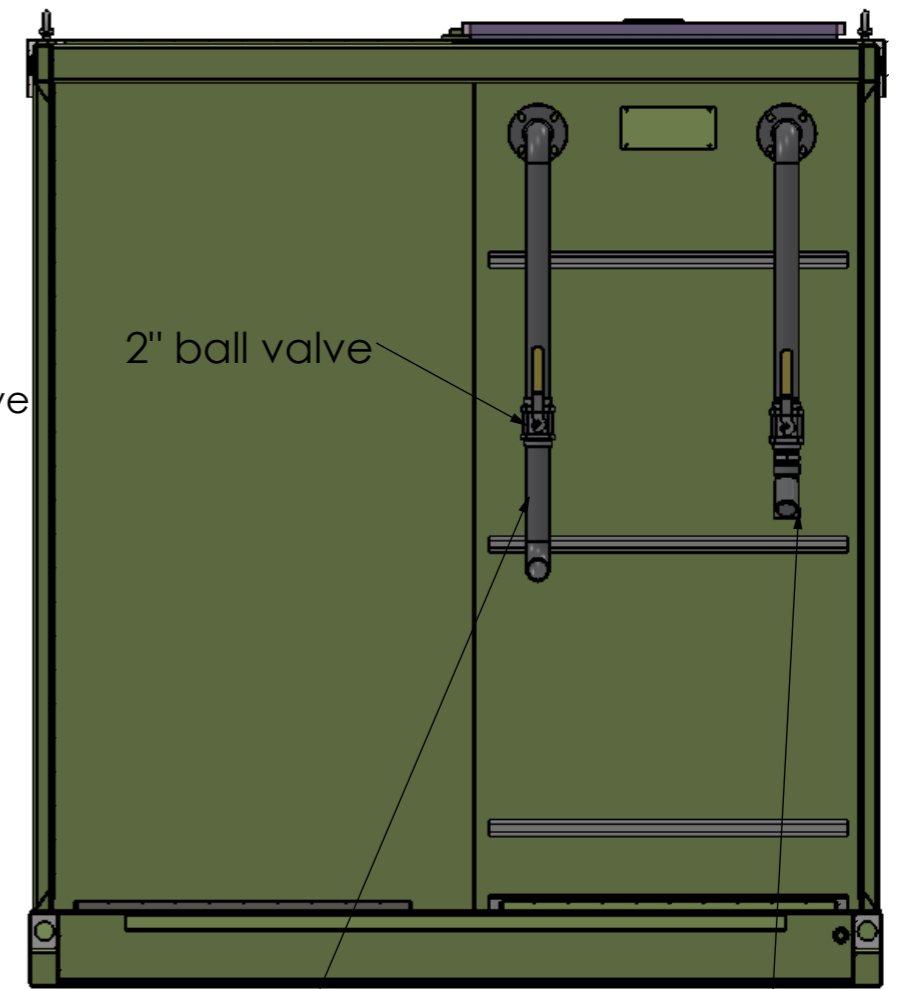

剖面 D-D

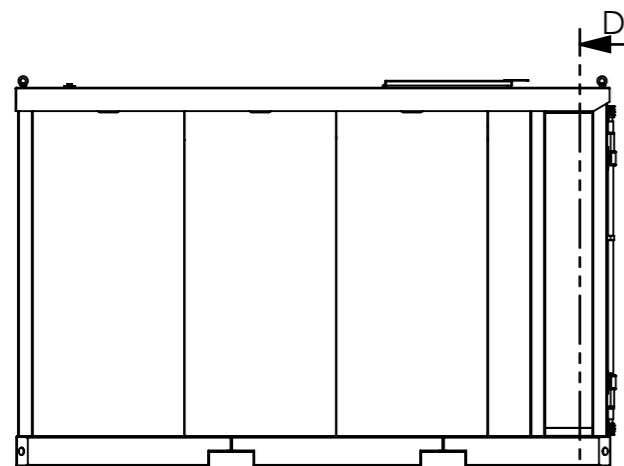
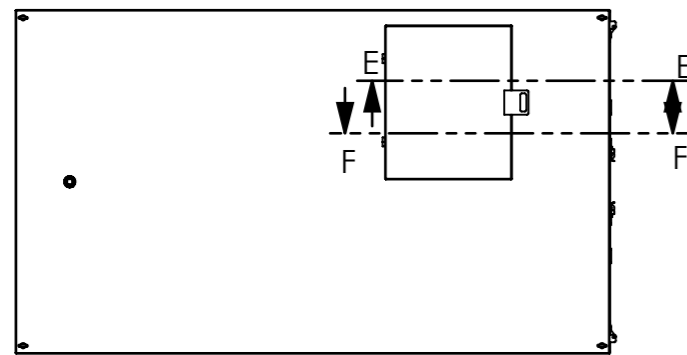

THIRD ANGLE PROJECTION		
DRAWN	2017/8/10	
CHK'D		
APPV'D		

PERFORMANCE U.N.O.	MATERIAL:
0 = -1.0	
0.0 = -0.4	
0.00 = -0.1	WEIGHT: Kg

DWG NO. / PART NO. ADBLUE AB-11 11,000L		JOB NO.
CLIENT:		
TITLE:		SHEET SIZE A3
SCALE: N.T.S.	SHEET 2 OF 2	
		REVISION